

2023

CATALOG

ELASTO
PROXY 

ELASTOPROXY.COM



CANADA

4035 Lavoisier Rue
Boisbriand, Québec,
Canada
J7H 1N1

Phone: (450) 434-2744
Fax: (450) 434-5998

CANADA

1145 Nicholson RD Unit 3
Newmarket, Ontario,
Canada
L3Y 9C3

Phone: (905) 898-1139
Fax: (905) 898-1004

USA

1021-C Old Stage Road
Simpsonville, South
Carolina, USA
29681-6044

Phone: (864) 228-5900
Fax: (864) 963-8992

BELGIUM

Heimolenstraat 127A
Unit 5, 9100 Sint-Niklaas

Phone: +32 (0) 3 301 01 83

TABLE OF CONTENTS

OUR STORY	03
DISCOVER OUR SEALS	04
BULB TRIM SEALS	06
ANTI-VIBRATION MOUNTS	40
BUMPERS	49
DUAL DUROMETERS	56
EDGE TRIMS	63
SILICONE HOSE CONNECTORS	74
SOLID PROFILES	79
SPONGE PROFILES	95
WINDOW CHANNELS	120
OUR COMMITMENTS	126
OUR TECHNOLOGY	129
PRODUCT OFFERING	130
FINISHED GASKETS	131
ADDED VALUE SERVICES	132
FABRICATION SERVICES	136



OUR STORY

Elasto Proxy is a family-owned company with deep roots, strong business relationships, and a growing global presence in the rubber and plastics industry. Founded in 1989 by Doug and Donna Sharpe, this “Mom and Pop shop” flourished in Quebec, Canada before expanding first to the Canadian province of Ontario and then to South Carolina in the United States. Today, we’re expanding our innovative business philosophy in Europe, where Elasto Proxy’s technical services and application knowledge will satisfy customers in the fastgrowing market.

OUR VALUE

Core values describe what we believe and guide the way that we act. These deeply-held values also serve as a mirror of sorts. When a company’s behavior reflects its core values, employees see this consistency. Customers and vendors recognize integrity, too. Inside and out, a company needs to be true in both word and deed.

That’s why at Elasto Proxy, we don’t just talk about our core values. We show you who we are in all that we do.

Maybe you’ve done business with Elasto Proxy for years. Maybe you’re a new customer or vendor. Regardless, we’d like you to know more about who we are and what our core values mean for you. Elasto Proxy is a growing, global company that’s powered by problem solvers. We’re also engaged, professional, and loyal. Regular readers of our blog have come to appreciate our application knowledge and technical expertise. But do you know how our core values support your success?



DISCOVER OUR SEALS



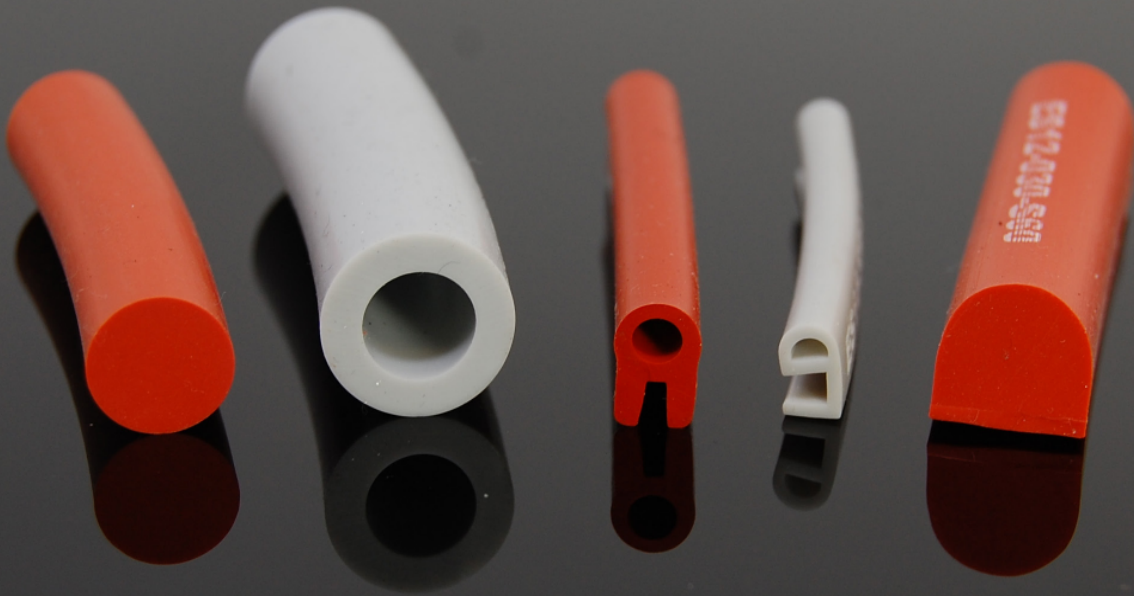

BULB TRIM SEALS

BULB TRIM SEALS > EC28-100-EM

BULB TRIM SEALS PART #: EC28 -100-EM



Material: EPDM Sponge
Width: As shown
Height: As shown
Stock: 2A3
Tolerance: RMA-BEC2
Scale: Not to Scale
Colour: Black
Duro: Medium 24A

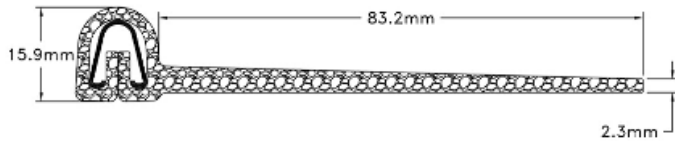

BULB TRIM SEALS > EC28-112-EM



BULB TRIM SEALS PART #: EC28 -112-EM

Material: EPDM
Width: As shown
Height: As shown
Tolerance: As shown
Scale: Not to Scale
Colour: Black
Duro: Dua

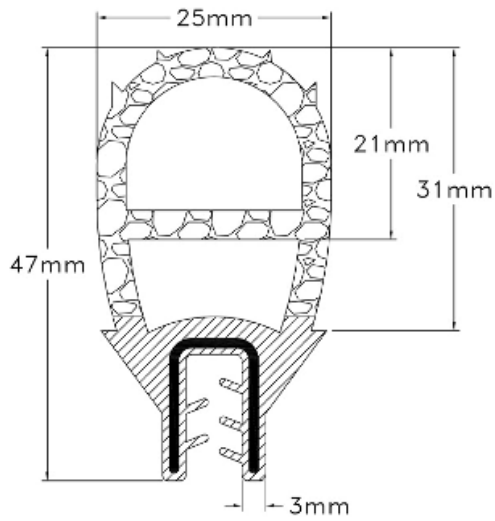

BULB TRIM SEALS > EC28-200-EM

BULB TRIM SEALS PART #: EC28 -200-EM

Material: EPDM Sponge
Width: As shown
Height: As shown
Scale: Not to Scale
Duro: Dual

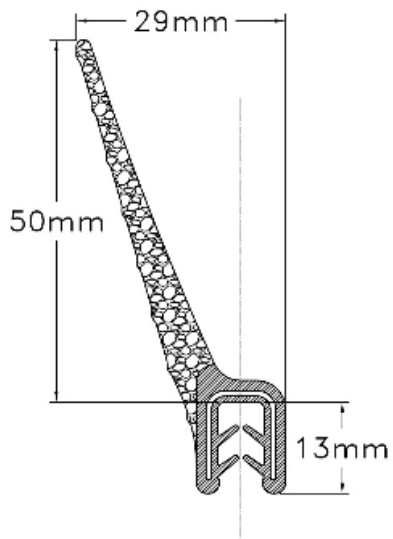

BULB TRIM SEALS > EC28-201-EM



BULB TRIM SEALS PART #: EC28 -201-EM

Material: EPDM
 Width: As shown
 Height: As shown
 Tolerance: RMA-E2
 Scale: Not to Scale
 Title: Trim Seal
 Colour: Black

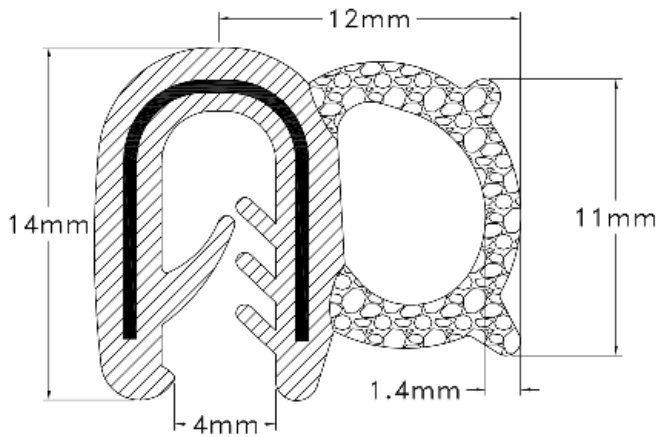

minimum bending radius			recommended plate thick	compression (N,at 25%)
35mm	35mm	-	1-3mm	6.73

BULB TRIM SEALS > EC28-204-EM



BULB TRIM SEALS PART #: EC28 -204-EM

Material: EPDM
 Width: As shown
 Height: As shown
 Tolerance: RMA-E2
 Scale: Not to Scale
 Colour: Black
 Duro: Dual

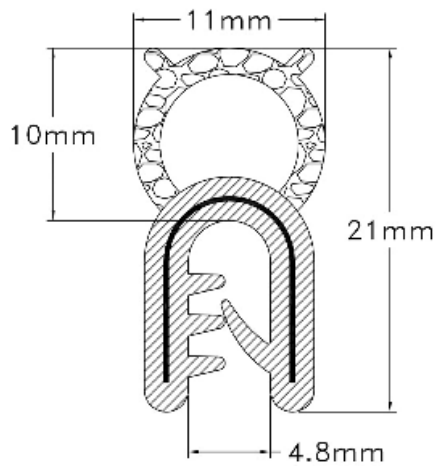

minimum bending radius			recommended plate thick	compression (N,at 25%)
				
-	-	25mm	1-2mm	2.84

BULB TRIM SEALS > EC28-208-EM



BULB TRIM SEALS PART #: EC28 -208-EM

Material: EPDM
 Width: As shown
 Height: As shown
 Tolerance: RMA-E2
 Scale: Not to Scale
 Colour: Black
 Duro: Medium

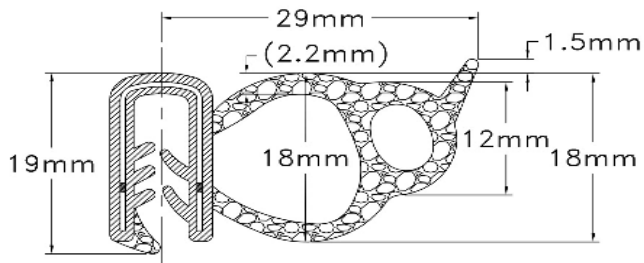

minimum bending radius		recommended plate thick	compression (N, at 25%)
			
45mm	65mm	-	1-3mm

BULB TRIM SEALS > EC28-210-EM



BULB TRIM SEALS PART #: EC28 -210-EM

Material: EPDM
 Width: As shown
 Height: As shown
 Tolerance: RMA-E2
 Scale: Not to Scale
 Title: Bulb Trim Seal
 Colour: Black
 Duro: Dual

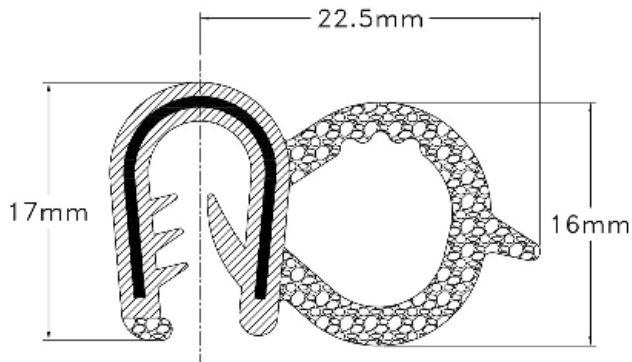

minimum bending radius			recommended plate thick	compression (N, at 25%)
				
25mm	55mm	—	5–6mm	—

BULB TRIM SEALS > EC28-212-EM



BULB TRIM SEALS PART #: EC28 -212-EM

Material: EPDM
 Width: As shown
 Height: As shown
 Tolerance: RMA-E3
 Scale: Not to Scale
 Colour: Black
 Duro: Medium

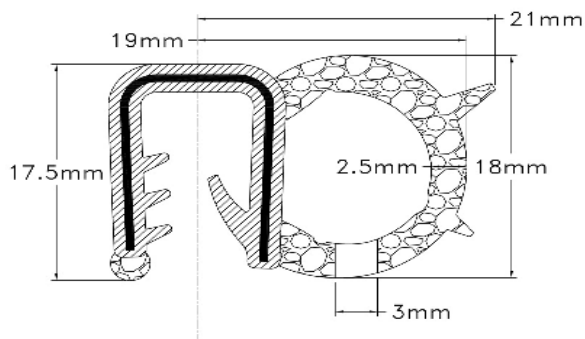

minimum bending radius			recommended plate thick	compression (N, at 25%)
25mm	45mm	—	5-6mm	4.71

BULB TRIM SEALS > EC28-213-EM



BULB TRIM SEALS PART #: EC28 -213-EM

Material: EPDM
 Width: As shown
 Height: As shown
 Tolerance: RMA-E2
 Scale: Not to Scale
 Colour: Black
 Duro: Dual

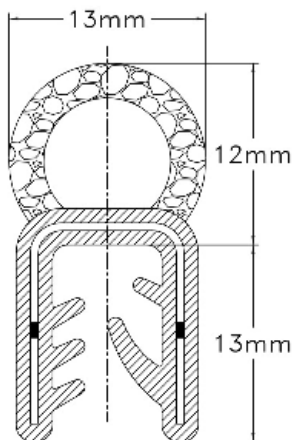

minimum bending radius			recommended plate thick	compression (N,at 25%)
				
-	-	25mm	3-6mm	2.59

BULB TRIM SEALS > EC28-215-EM



BULB TRIM SEALS PART #: EC28 -215-EM

Material: EPDM

Width: As shown

Height: As shown

Tolerance: RMA-E2

Scale: Not to Scale

Colour: Black

Duro: Dual

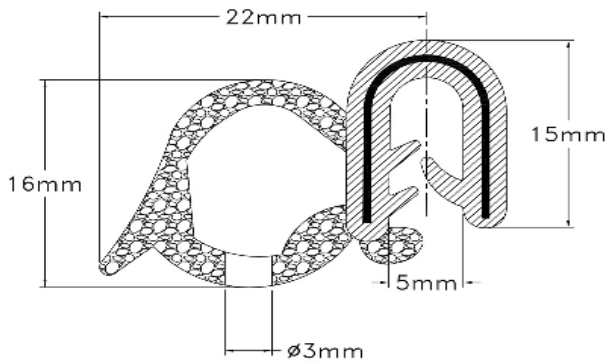

minimum bending radius			recommended plate thick	compression (N,at 25%)
①	②	③		
35mm	65mm	—	1-5mm	3.62

BULB TRIM SEALS > EC28-220-EM



BULB TRIM SEALS PART #: EC28 -220-EM

Material: EPDM
Width: As shown
Height: As shown
Tolerance: RMA-E2
Scale: Not to Scale
Colour: Black
Duro: Dual

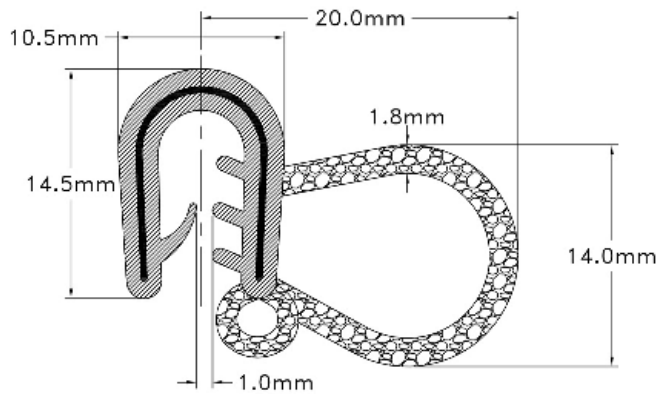

BULB TRIM SEALS > EC28-222-EM



BULB TRIM SEALS PART #: EC28 -222-EM

Material: EPDM

Width: As shown

Height: As shown

Tolerance: RMA-E3

Scale: Not to Scale

Colour: Black

Duro: Dual

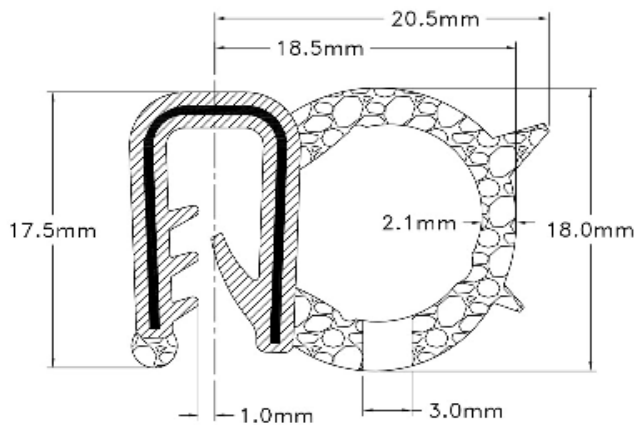

minimum bending radius			recommended plate thick	compression (N, at 25%)
25mm	45mm	—	2-4mm	—

BULB TRIM SEALS > EC28-230-EM



BULB TRIM SEALS PART #: EC28 -230-EM

Material: EPDM Solid

Width: As shown

Height: As shown

Tolerance: RMA-E2

Scale: Not to Scale

Colour: Black

Duro: 70 ±5

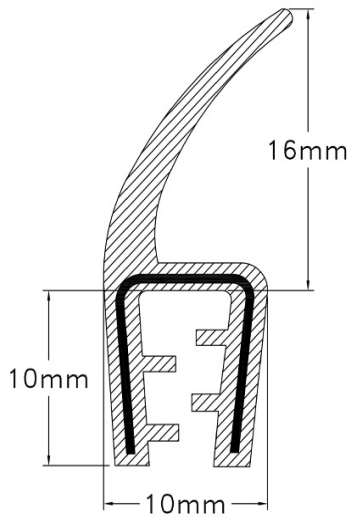

minimum bending radius			recommended plate thick	compression (N, at 25%)
				
-	-	35mm	-	-

BULB TRIM SEALS > EC28-240-EM



BULB TRIM SEALS PART #: EC28 -240-EM

Material: EPDM

Width: As shown

Height: As shown

Tolerance: RMA-E2

Scale: Not to Scale

Colour: Black

Duro: Dual

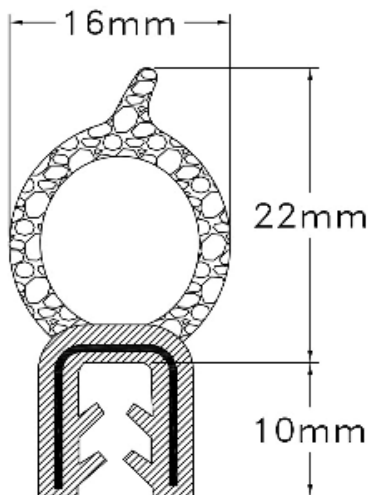

minimum bending radius			recommended plate thick	compression (N, at 25%)
-	-	35mm	3-5mm	1.57

BULB TRIM SEALS > EC28-250-EM



BULB TRIM SEALS PART #: EC28 -250-EM

Material: EPDM
 Width: As shown
 Height: As shown
 Tolerance: RMA-E2
 Scale: Not to Scale
 Colour: Black
 Duro: Medium

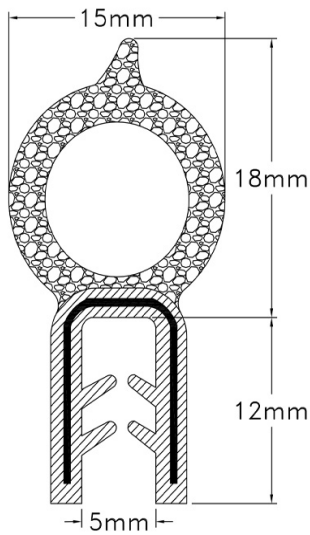

minimum bending radius			recommended plate thick	compression (N,at 25%)
—	—	35mm	1–3mm	5.23

BULB TRIM SEALS > EC28-260-EM



BULB TRIM SEALS PART #: EC28 -260-EM

Material: EPDM

Width: As shown

Height: As shown

Tolerance: RMA-E2

Scale: Not to Scale

Colour: Black

Duro: Dual

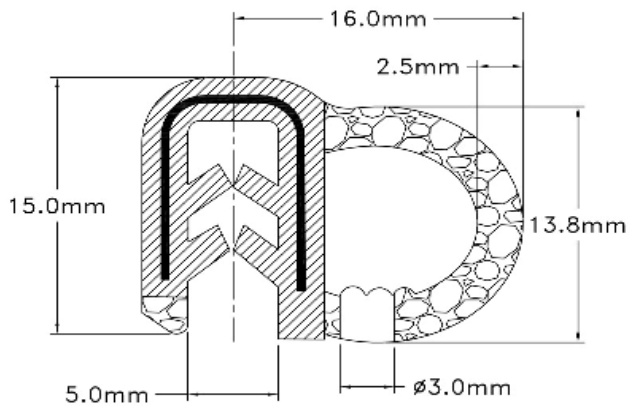

minimum bending radius			recommended plate thick	compression (N,at 25%)
① 	② 	③ 		
25mm	45mm	-	2-4mm	3.88

BULB TRIM SEALS > EC28-270-EM



BULB TRIM SEALS PART #: EC28 -270-EM

Material: EPDM
 Width: As shown
 Height: As shown
 Tolerance: RMA-E2
 Scale: Not to Scale
 Colour: Black
 Duro: Dual

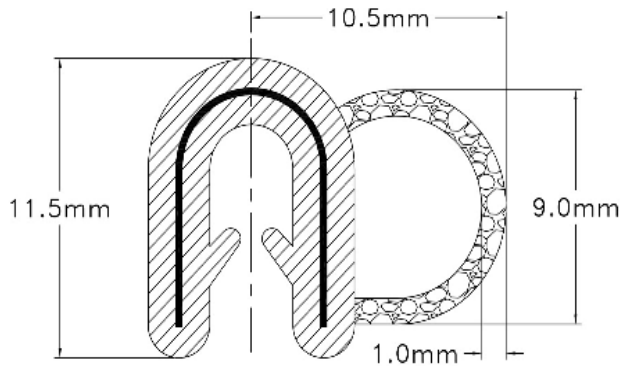

minimum bending radius			recommended plate thick	compression (N,at 25%)
				
15mm	25mm	-	1-2mm	4.66

BULB TRIM SEALS > EC28-271-EM



BULB TRIM SEALS PART #: EC28 -271-EM

Material: EPDM
 Width: As shown
 Height: As shown
 Tolerance: As shown
 Scale: Not to Scale
 Colour: Black
 Duro: Dual

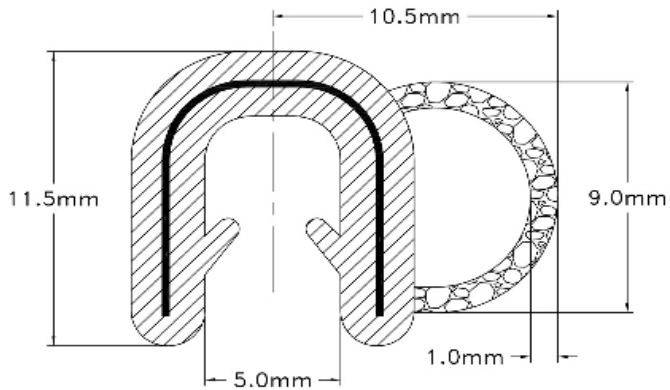

Minimum Bending Radius (mm)			Recommended Plate Thickness (mm)	Extraction Force at Min. Plate Thickness (N)	Extraction Force at Max. Plate Thickness (N)	Compression Force (N, at 25%)
①	②	③				
15MM	25MM	-	2-3MM	MIN	MAX	-

BULB TRIM SEALS > EC28-274-EM



BULB TRIM SEALS PART #: EC28 -274-EM

Material: EPDM
 Width: As shown
 Height: As shown
 Tolerance: RMA-E2
 Scale: Not to Scale
 Colour: Black
 Duro: Dual

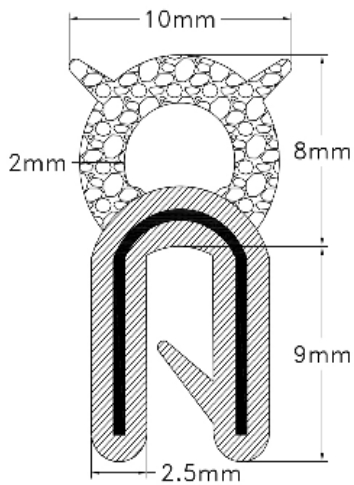

minimum bending radius			recommended plate thick	compression (N,at 25%)
-	-	15mm	1-2mm	-

BULB TRIM SEALS > EC28-280-EM



BULB TRIM SEALS PART #: EC28 -280-EM

Material: EPDM
 Width: As shown
 Height: As shown
 Tolerance: RMA-E2
 Scale: Not to Scale
 Colour: Black
 Duro: Dual

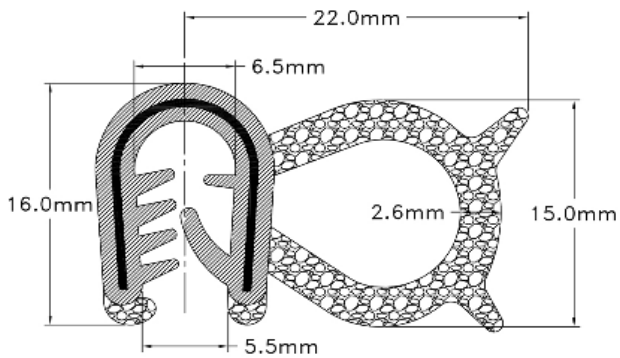

minimum bending radius			recommended plate thick	compression (N,at 25%)
45mm	45mm	—	1-5mm	—

BULB TRIM SEALS > EC28-290-EM



BULB TRIM SEALS PART #: EC28 -290-EM

Material: EPDM
 Width: As shown
 Height: As shown
 Tolerance: As shown
 Scale: Not to Scale
 Colour: Black
 Duro: Dual

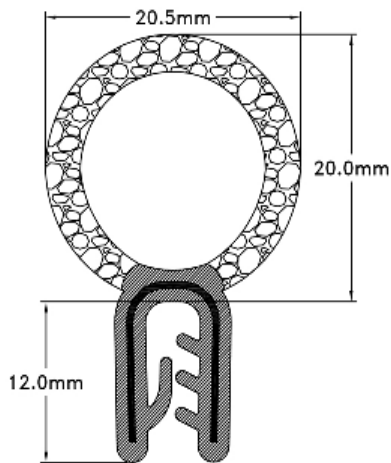

Minimum Bending Radius (mm)			Recommended Plate Thickness (mm)	Extraction Force at Min. Plate Thickness (N)	Extraction Force at Max. Plate Thickness (N)	Compression Force (N. at 25%)
-	-	35mm	1.5mm	MIN	MAX	-

BULB TRIM SEALS > EC28-315-EM



BULB TRIM SEALS PART #: EC28 -315-EM

Material: EPDM

Width: As shown

Height: As shown

Tolerance: RMA-E2

Scale: Not to Scale

Colour: Black

Duro: Dual

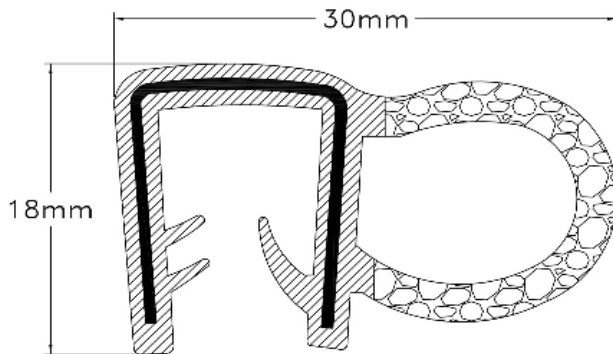

minimum bending radius			recommended plate thick	compression (N,at 25%)
①	②	③		
55mm	55mm	—	6-9mm	—

BULB TRIM SEALS > EC28-320-EM



BULB TRIM SEALS PART #: EC28 -320-EM

Material: EPDM
 Width: As shown
 Height: As shown
 Tolerance: RMA-E3
 Scale: Not to Scale
 Colour: Black
 Duro: Dual

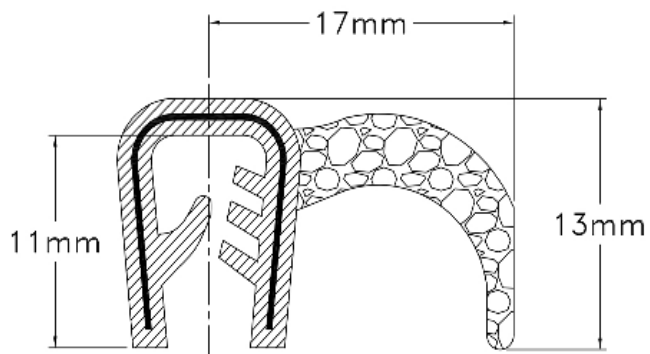

minimum bending radius			recommended plate thick	compression (N,at 25%)
				
45mm	45mm	—	1-4mm	—

BULB TRIM SEALS > EC28-405-EM



BULB TRIM SEALS PART #: EC28 -405-EM

Material: EPDM
 Width: As shown
 Height: As shown
 Tolerance: As shown
 Scale: Not to Scale
 Colour: Black
 Duro: Dual

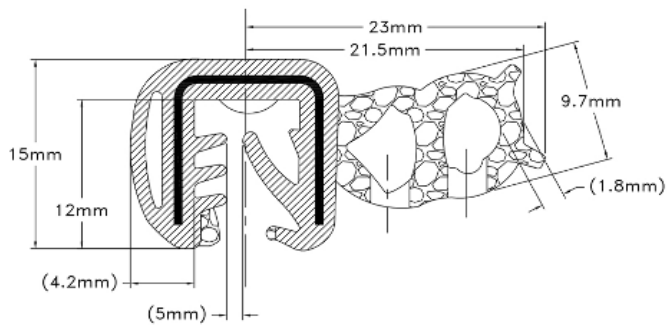

minimum bending radius			recommended plate thick	compression (N,at 25%)
				
15mm	35mm	—	5–6mm	3.51

BULB TRIM SEALS > EC28-410-EM



BULB TRIM SEALS PART #: EC28 -410-EM

Material: EPDM
 Width: As shown
 Height: As shown
 Tolerance: As shown
 Scale: Not to Scale
 Colour: Black
 Duro: Dual

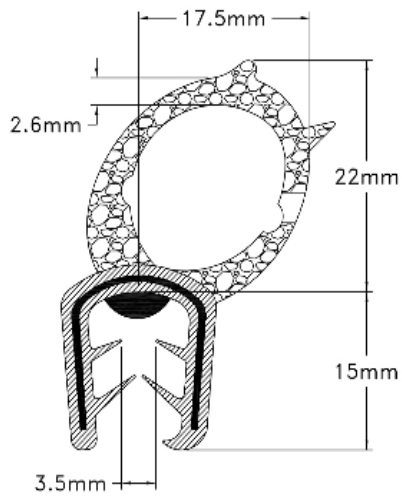

minimum bending radius			recommended plate thick	compression (N, at 25%)
①	②	③		
-	-	35mm	-	-

BULB TRIM SEALS > EC28-415-EM



BULB TRIM SEALS PART #: EC28 -415-EM

Material: EPDM
 Width: As shown
 Height: As shown
 Tolerance: RMA-E2
 Scale: Not to Scale
 Colour: Black
 Duro: Dual

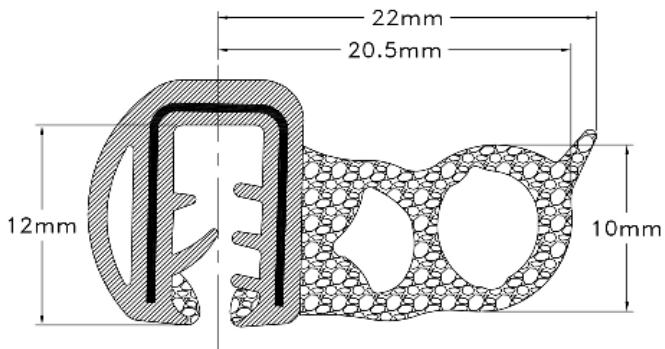

minimum bending radius			recommended plate thick	compression (N,at 25%)
				
15mm	25mm	—	2-3mm	—

BULB TRIM SEALS > EC28-420-EM

BULB TRIM SEALS PART #: EC28 -420-EM

Material: EPDM
Width: As shown
Height: As shown
Tolerance: RMA-E2
Scale: Not to Scale
Colour: Black
Duro: Medium

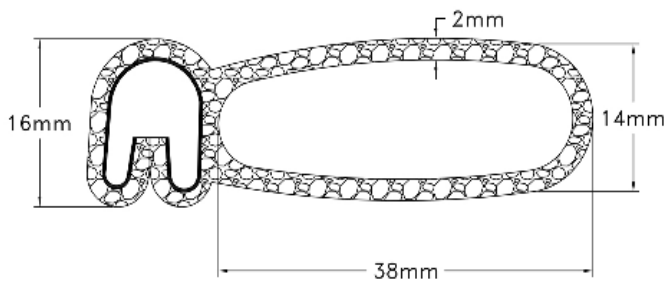

BULB TRIM SEALS > EC28-503-EM



BULB TRIM SEALS PART #: EC28 -503-EM

Material: EPDM
 Width: As shown
 Height: As shown
 Tolerance: RMA-E2
 Scale: Not to Scale
 Colour: Black
 Duro: Dual

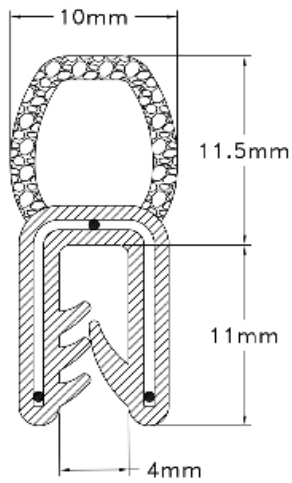

minimum bending radius			recommended plate thick	compression (N, at 25%)
-	-	25mm	1-3mm	-

BULB TRIM SEALS > EC28-511-EM

BULB TRIM SEALS PART #: EC28 -511-EM

Material: EPDM
Width: As shown
Height: As shown
Tolerance: As shown
Scale: Not to Scale
Colour: Black
Duro: Dual

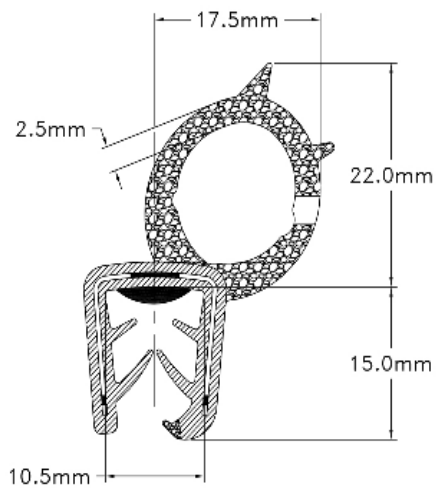

BULB TRIM SEALS > EC28-975-EM



BULB TRIM SEALS PART #: EC28 -511-EM

Material: EPDM
Width: As shown
Height: As shown
Tolerance: RMA-E2
Scale: Not to Scale
Colour: Black
Duro: Dual Duro

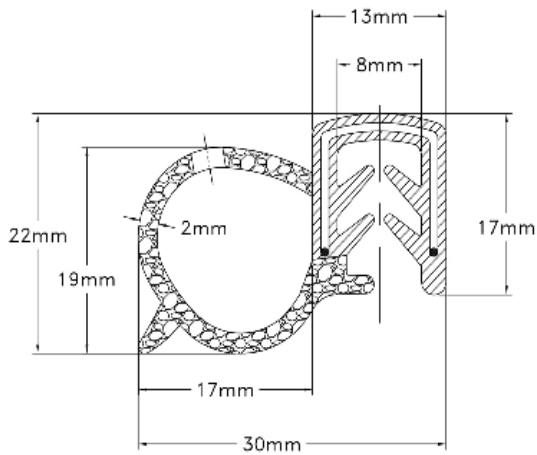

BULB TRIM SEALS

RUBBER TYPE: CELLULAR EPDM

ASTM D 1056 2A3 B2

DESCRIPTION	ASTM TEST	UNIT	MIN.	MAX.
DENSITY	D 1667	g/cm ³	0.5	0.52
HARDNESS	D 2240	Sh A	-	-
COMPRESSION SET, 22 hours @ 70°C	D 395 b	Percentage		25
TENSILE STRENGTH	D 412	N/mm ²	7	
ELONGATION	D 412	Percentage	500	
TEAR RESISTANCE	D 624	N/mm ²	20	
COMPRESSION SET, 22 hours @ -20°C	D 395 b	Percentage		25
AGING TEST, 70 hours @ 70°C	D 454			
<i>Density</i>	D 1667	g/cm	0.48	0.53
<i>Hardness</i>	D 2240	Sh A	-	-
<i>Tensile Strength</i>	D 412	N/mm ²	5	9
<i>Elongation</i>	D 412	Percentage	250	
<i>Tear Resistance</i>	D 624	N/mm ²	20	
TEMPERATURE RESISTANCE		°C	-	-
OZONE RESISTANCE	D 1149	-	No crack	
BRITTLE POINT	D 746	°C	-40	

Information obtained herein is based on data, which we believe to be reliable. Seeing as this compound may be used in many different and use applications, alone, or in conjunction with other products, we cannot guarantee the same results will be obtained. It is recommended that each user make their own tests to determine the suitability and/or performance acceptance of this material for their particular application.

BULB TRIM SEALS

RUBBER TYPE: SOLID EPDM

ASTM D 2000 M2 AA 810 A13 B13 F17

DESCRIPTION	ASTM TEST	UNIT	MIN.	MAX.
DENSITY	D 1667	g/cm ³	1.1	1.3
HARDNESS	D 2240	Sh A	55	65
COMPRESSION SET, 22 hours @ 70°C	D 395 b	Percentage	-	25
TENSILE STRENGTH	D 412	N/mm ²	10	-
ELONGATION	D 412	Percentage	350	-
TEAR RESISTANCE	D 624	N/mm ²		-
COMPRESSION SET, 22 hours @ -20°C	D 395 b	Percentage	-	-
AGING TEST, 70 hours @ 70°C	D 454			
<i>Density</i>	D 1667	g/cm	1.1	1.3
<i>Hardness</i>	D 2240	Sh A	45	75
<i>Tensile Strength</i>	D 412	N/mm ²	6	10
<i>Elongation</i>	D 412	Percentage	175	-
<i>Tear Resistance</i>	D 624	N/mm ²	-	-
TEMPERATURE RESISTANCE		°C	-	-
OZONE RESISTANCE	D 1149	-	-	-
BRITTLE POINT	D 746	°C	-	-

Information obtained herein is based on data, which we believe to be reliable. Seeing as this compound may be used in many different and use applications, alone, or in conjunction with other products, we cannot guarantee the same results will be obtained. It is recommended that each user make their own tests to determine the suitability and/or performance acceptance of this material for their particular application.

BULB TRIM SEALS

TYPE: METALLIC INSERT 26mm

DIN 1624 U St3 K50

DESCRIPTION	NORM	INTERN. NORM	MIN.	MAX.
THICKNESS	D 1667	mm	0.465	0.535
ROCKWELL HARDNESS	D 2240	HRB	80	90
TENSILE STRENGTH	D 395 b	Kg/mm ²	49	59
WIDTH	D 412	mm	25.8	26.2

Information obtained herein is based on data, which we believe to be reliable. Seeing as this compound may be used in many different and use applications, alone, or in conjunction with other products, we cannot guarantee the same results will be obtained. It is recommended that each user make their own tests to determine the suitability and/or performance acceptance of this material for their particular application.

ANTI-VIBRATION MOUNTS

ANTI-VIBRATION MOUNTS > VM2-FF2020-R60

ANTI-VIBRATION MOUNTS PART #: VM2-FF2020-R60



Material: Natural Rubber/Steel

Width: As shown

Height: As shown

Tolerance: RMA-A2

Scale: Not to Scale

Colour: Black

Duro: 60±5

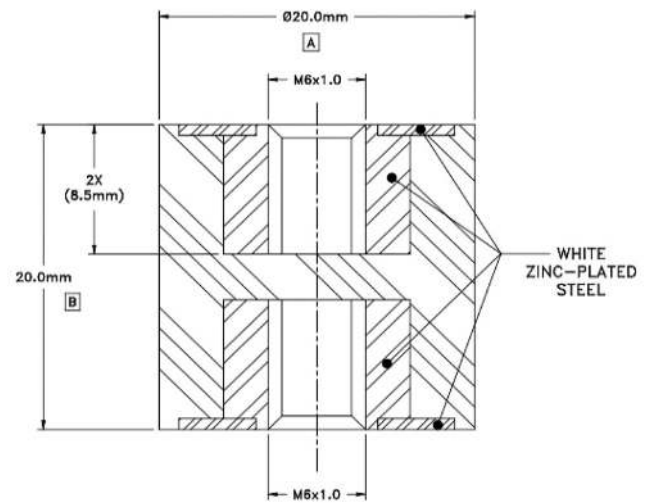

ANTI-VIBRATION MOUNTS > VM2-MF1530-R50

ANTI-VIBRATION MOUNTS PART #: VM2-MF1530-R50



Material: Natural Rubber/Steel

Width: As shown

Height: As shown

Tolerance: RMA-A2

Scale: Not to Scale

Colour: Black

Duro: 50±5

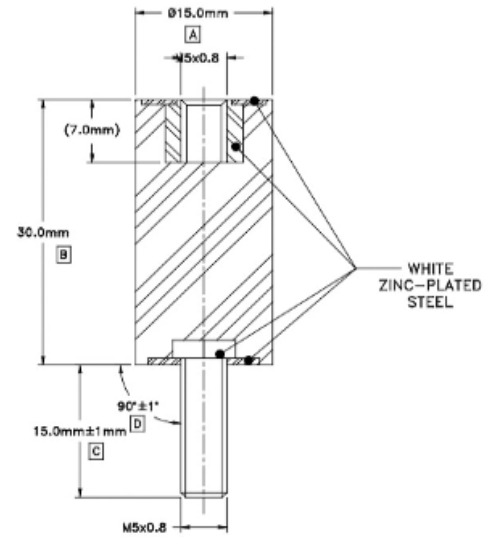

ANTI-VIBRATION MOUNTS > VM2-MM0808-R60

ANTI-VIBRATION MOUNTS PART #: VM2-MM0808-R60



Material: Natural Rubber/Steel

Width: As shown

Height: As shown

Tolerance: RMA-A2

Scale: Not to Scale

Colour: Black

Duro: 60±5

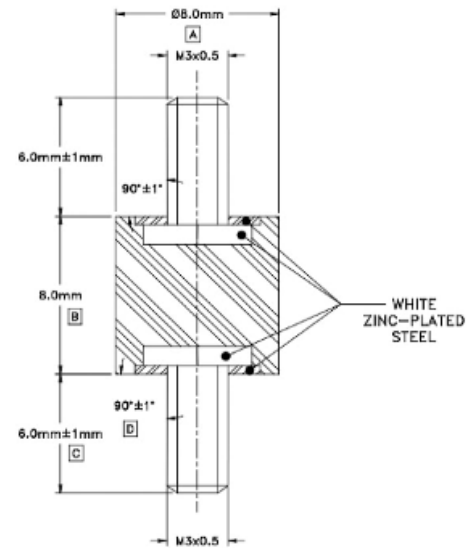

ANTI-VIBRATION MOUNTS > VM2-MM2510-R60

ANTI-VIBRATION MOUNTS PART #: VM2-MM2510-R60



Material: Natural Rubber/Steel

Width: As shown

Height: As shown

Tolerance: RMA-A2

Scale: Not to Scale

Colour: Black

Duro: 50±5

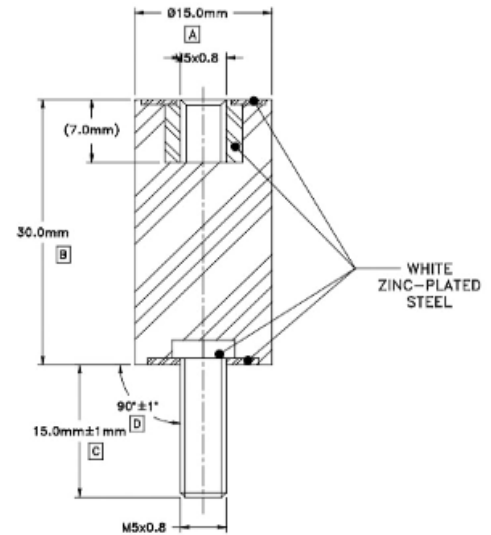

ANTI-VIBRATION MOUNTS > VM2-MM2525-R50

ANTI-VIBRATION MOUNTS PART #: VM2-MM2525-R50



Material: Natural Rubber/Steel

Width: As shown

Height: As shown

Tolerance: RMA-A2

Scale: Not to Scale

Colour: Black

Duro: 50±5

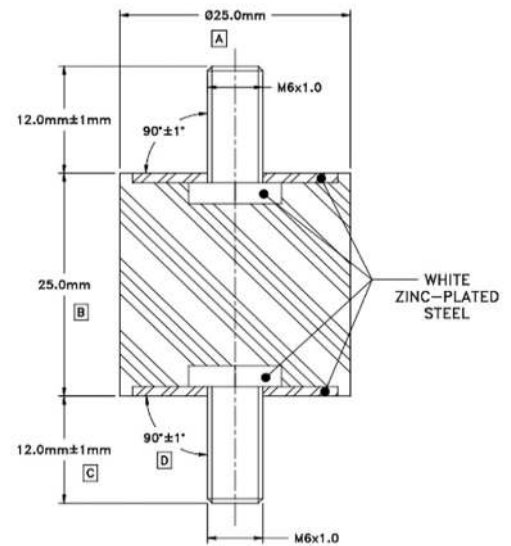

ANTI-VIBRATION MOUNTS > VM4-6330-R60

ANTI-VIBRATION MOUNTS PART #: VM4-6330-R60



Material: Neoprene/Steel

Width: As shown

Height: As shown

Tolerance: RMA-A2

Scale: Not to Scale

Colour: Black/Steel

Duro: 60±5

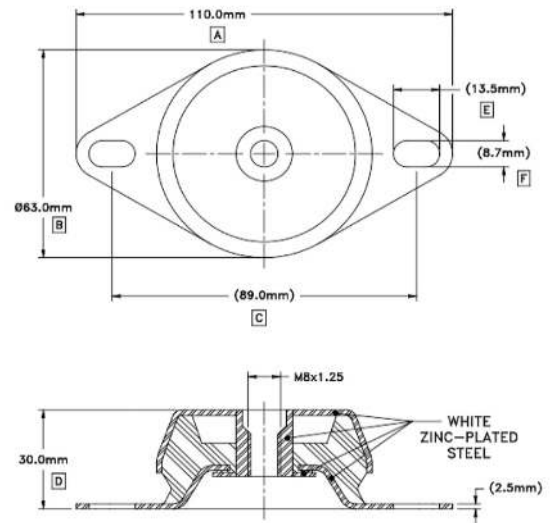

ANTI-VIBRATION MOUNTS > VM4-3038-R60

ANTI-VIBRATION MOUNTS PART #: VM4-3038-R60



Material: Natural Rubber/Steel

Width: As shown

Height: As shown

Tolerance: RMA-A2

Scale: Not to Scale

Colour: Black

Duro: 60±5

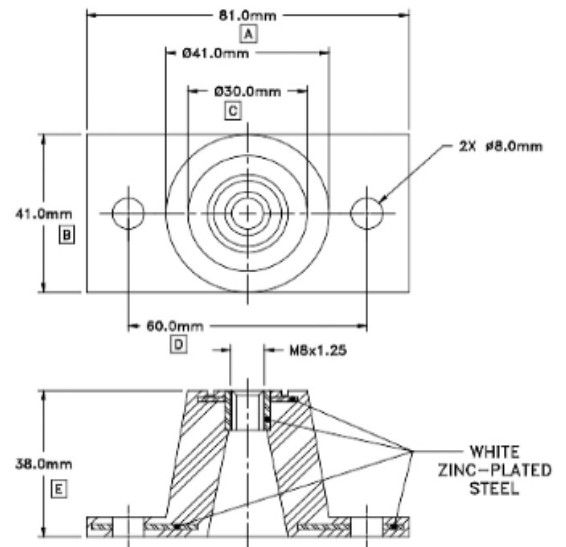

ANTI-VIBRATION MOUNTS > VM5-3027-R60

ANTI-VIBRATION MOUNTS PART #: VM5-3027-R60



Material: Natural Rubber/Steel

Width: As shown

Height: As shown

Tolerance: RMA-A2

Scale: Not to Scale

Colour: Black

Duro: 60±5

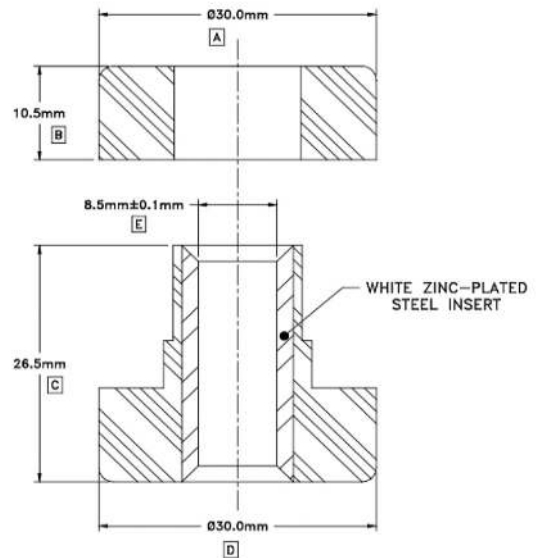

BUMPERS

BUMPERS > MB-220-C80

BUMPERS PART #: MB-220-C80



Material: SBR
Width: As shown
Height: As shown
Tolerance: RMA-A2
Scale: Not to Scale
Colour: Black
Duro: 80±5

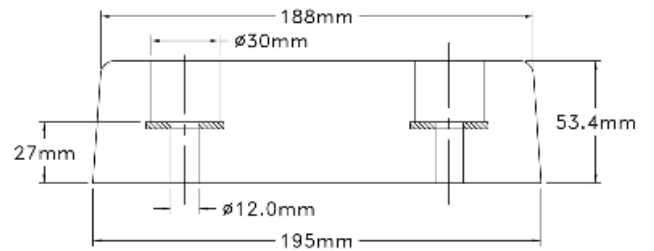
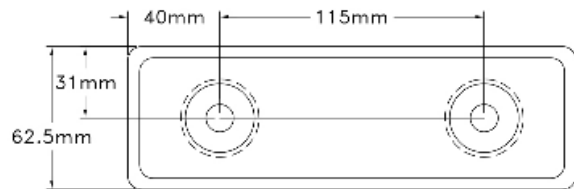

BUMPERS > MB-230-C80

BUMPERS PART #: MB-230-C80



Material: SBR
Width: As shown
Height: As shown
Tolerance: RMA-A2
Scale: Not to Scale
Colour: Black
Duro: 80±5

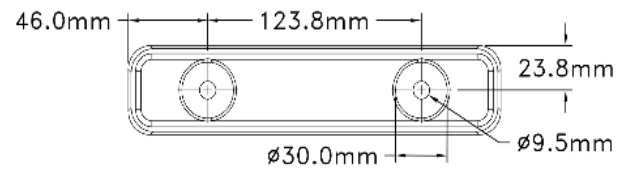

BUMPERS > MB-230-C80

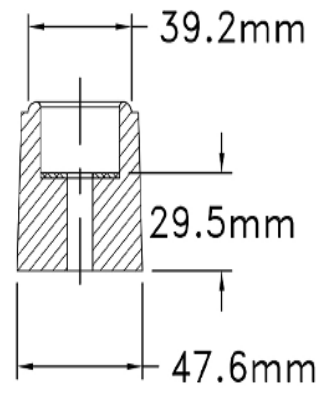
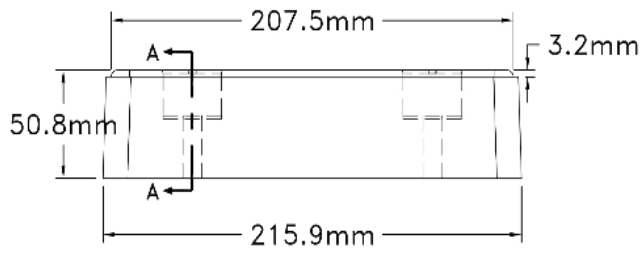

BUMPERS > MB-240-C80

BUMPERS PART #: MB-240-C80



Material: SBR
Width: As shown
Height: As shown
Tolerance: RMA-A2
Scale: Not to Scale
Colour: Black
Duro: 80±5

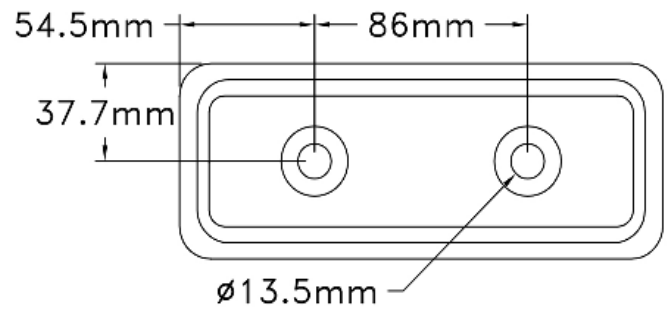

BUMPERS > MB-240-C80

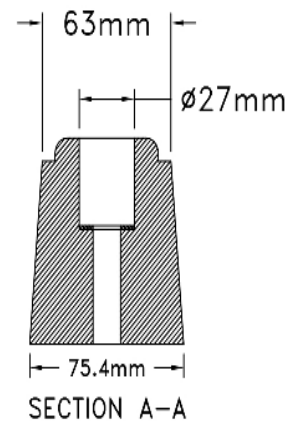
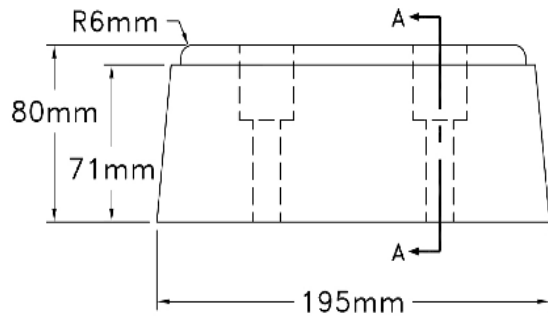

BUMPERS > MB-290-C80

BUMPERS PART #: MB-290-C80



Material: SBR
Width: As shown
Height: As shown
Tolerance: RMA-A2
Scale: Not to Scale
Colour: Black
Duro: 80±5

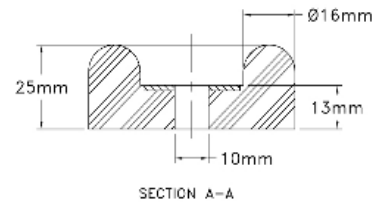
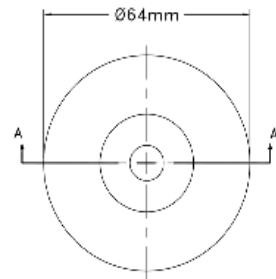

DUAL DUROMETER RUBBER

DUAL DUROMETER RUBBER > EC04-100-EM



DUAL DUROMETER RUBBER PART #: EC04-100-EM

Material: EPDM
 Width: As shown
 Height: As shown
 Tolerance: RMA-E2
 Scale: Not to Scale
 Colour: Black
 Duro: Dual

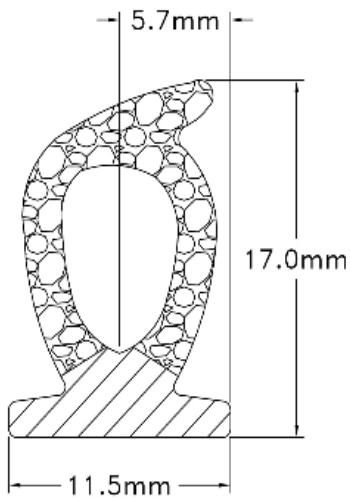

minimum bending radius			recommended plate thick	compression (N,at 25%)
				
-	-	25mm	-	-

DUAL DUROMETER RUBBER > EC04-105-EM



DUAL DUROMETER RUBBER PART #: EC04-105-EM

Material: EPDM
Width: As shown
Height: As shown
Tolerance: RMA-BEC2
Scale: Not to Scale
Colour: Black
Duro: Dual

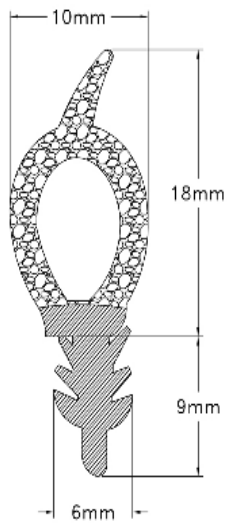

DUAL DUROMETER RUBBER > EC12-122-EMT1



DUAL DUROMETER RUBBER PART #: EC12-122-EMT1

Material: EPDM

Width: As shown

Height: As shown

Tolerance: RMA-E2

Scale: Not to Scale

Colour: Black

Duro: Dual

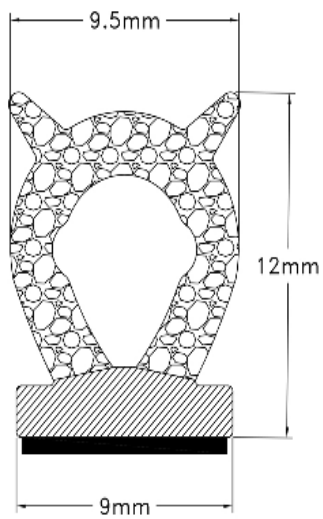

DUAL DUROMETER RUBBER > EC04-190-EMT1



DUAL DUROMETER RUBBER PART #: EC04-190-EMT1

Material: EPDM
 Width: As shown
 Height: As shown
 Tolerance: RMA-BEC2
 Scale: Not to Scale
 Colour: Black
 Duro: Dual

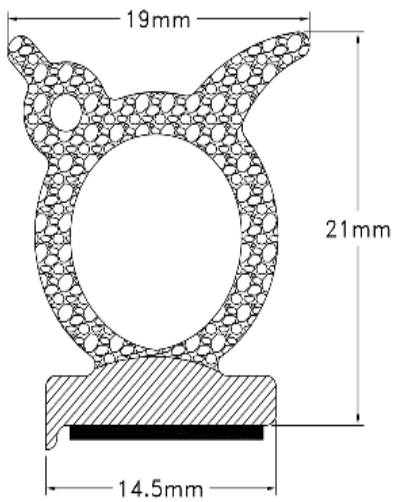

minimum bending radius			recommended plate thick	compression (N, at 25%)
-	-	45mm	-	-

DUAL DUROMETER RUBBER > EC04-597-EMT1



DUAL DUROMETER RUBBER PART #: EC04-597-EMT1

Material: EPDM
Width: As shown
Height: As shown
Tolerance: As shown
Scale: Not to Scale
Colour: Black
Duro: Dual

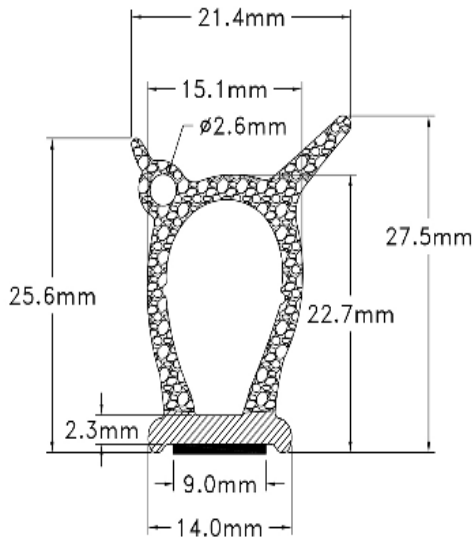

DUAL DUROMETER RUBBER > EC12-443-PMT

DUAL DUROMETER RUBBER PART #: EC12-443-PMT

Material: Plastic
Width: As shown
Height: As shown
Tolerance: RMA-E2
Scale: Not to Scale
Colour: Black
Duro: Dual

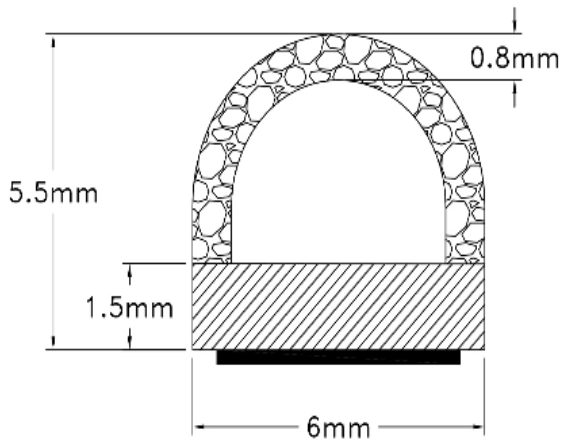

EDGE TRIM

EDGE TRIM > ES28-110-P60



EDGE TRIM PART #: ES28-110-P60

Material: PVC
Width: As shown
Height: As shown
Tolerance: RMA-E2
Scale: Not to Scale
Colour: Black
Duro: Dual

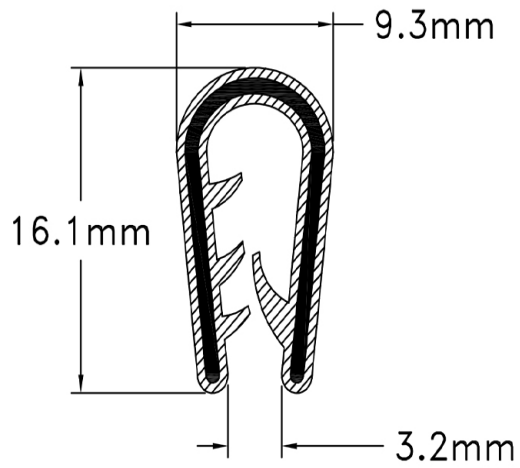

EDGE TRIM > ES28-126-P60

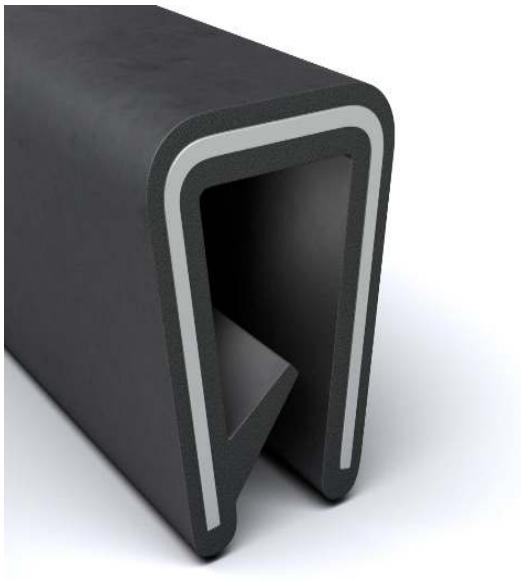

EDGE TRIM PART #: ES28-126-P60

Material: Vinyl
Width: As shown
Height: As shown
Tolerance: RMA-E2
Scale: Not to Scale
Colour: Black
Duro: 60±5

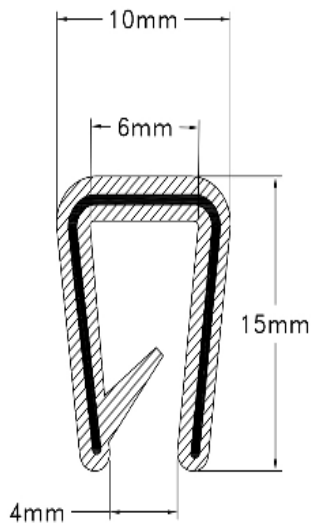

EDGE TRIM > ES28-128-P60



EDGE TRIM PART #: ES28-128-P60

Material: Vinyl
Width: As shown
Height: As shown
Tolerance: RMA-E2
Scale: Not to Scale
Colour: Black
Duro: 60 \pm 5

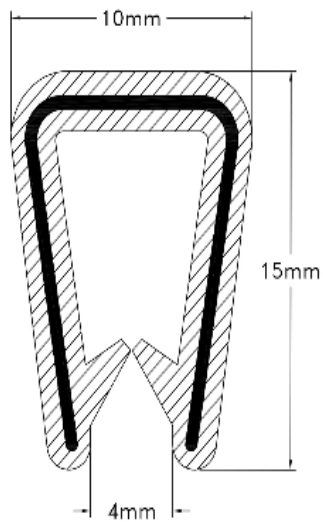

EDGE TRIM > ES28-132-P60



EDGE TRIM PART #: ES28-132-P60

Material: Vinyl
Width: As shown
Height: As shown
Tolerance: RMA-E2
Scale: Not to Scale
Colour: Black
Duro: 80±5

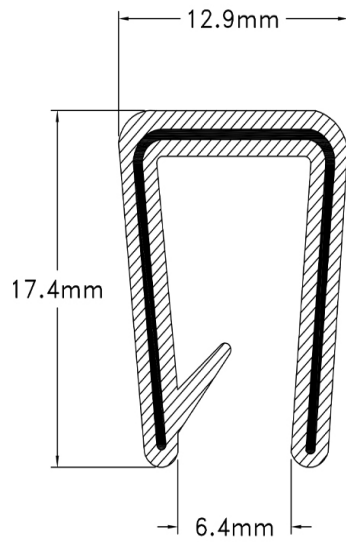



EDGE TRIM > ES28-140-P60



EDGE TRIM PART #: ES28-140-P60

Material: PVC
 Width: As shown
 Height: As shown
 Tolerance: RMA-E2
 Scale: Not to Scale
 Colour: Black
 Duro: 80±5

minimum bending radius			recommended plate thick	compression (N,at 25%)
① 	② 	③ 		
15mm	25mm	15mm	1-2mm	-

EDGE TRIM > ES28-186-P80

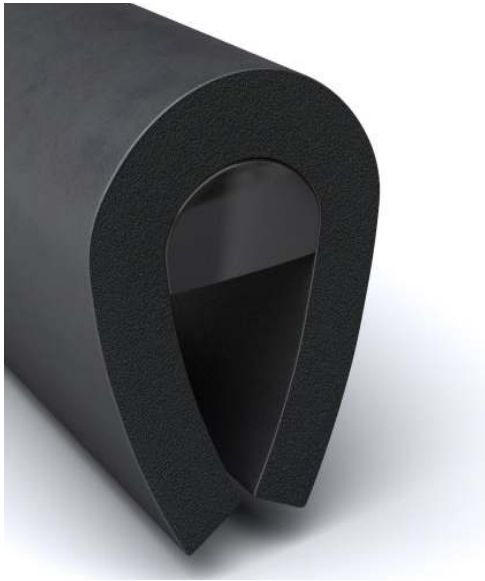

EDGE TRIM PART #: ES28-186-P80

Material: PVC
Width: As shown
Height: As shown
Tolerance: $\pm .015''$
Scale: Not to Scale
Colour: Black
Duro: 80 ± 5

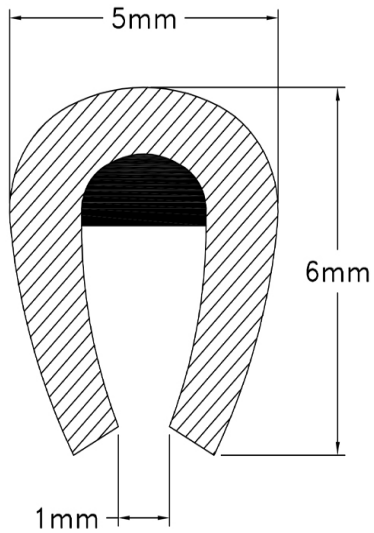

EDGE TRIM > ES28-210-P80



EDGE TRIM PART #: ES28-210-P80

Material: PVC
Width: As shown
Height: As shown
Tolerance: $\pm 0.015''$
Scale: Not to Scale
Colour: Black Gloss Finish
Duro: 80 ± 5

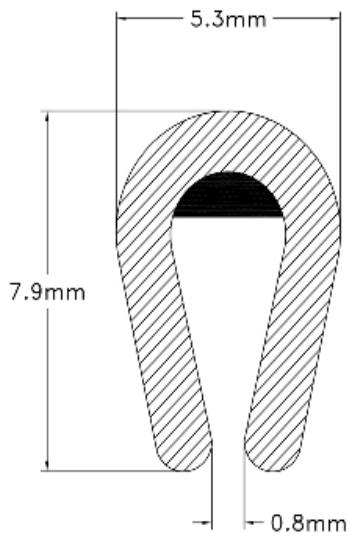

EDGE TRIM > ES28-215-P80

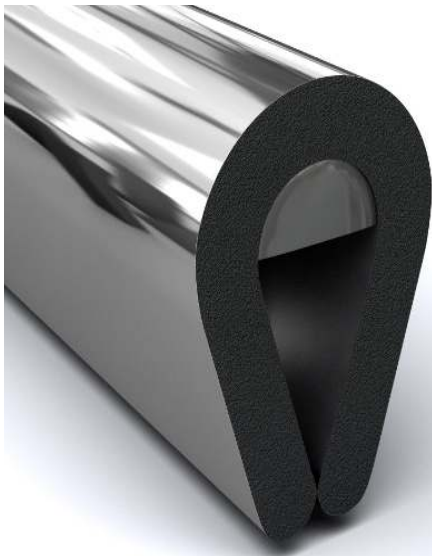

EDGE TRIM PART #: ES28-215-P80

Material: PVC
Width: As shown
Height: As shown
Tolerance: $\pm 0.015''$
Scale: Not to Scale
Colour: Chrome
Duro: 80 ± 5

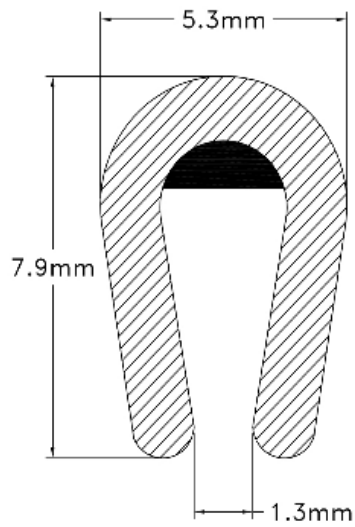

EDGE TRIM > ES28-280-P80



EDGE TRIM PART #: ES28-280-P80

Material: PVC
Width: As shown
Height: As shown
Tolerance: $\pm 0.015''$
Scale: Not to Scale
Colour: Black
Duro: 80 ± 5

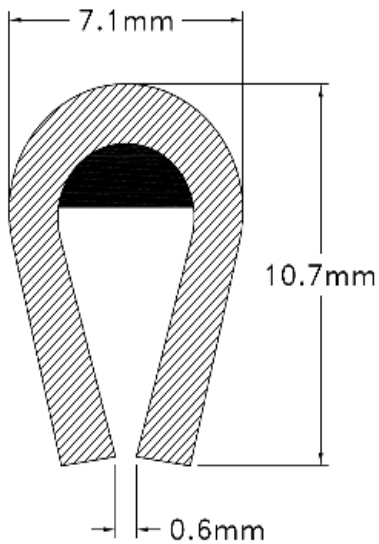

EDGE TRIM > ES28-403-P80



EDGE TRIM PART #: ES28-403-P80

Material: TPE FDA
Width: As shown
Height: As shown
Tolerance: RMA-E2
Scale: Not to Scale
Colour: Black
Duro: 70±5

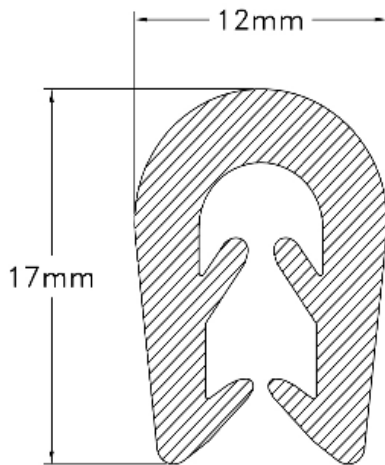

SILICONE HOSE CONNECTORS

SILICONE HOSE CONNECTORS > HC-222-S

SILICONE HOSE CONNECTORS PART #: HC-222-S



Material: 4 Ply Aramid

Width: As shown

Height: As shown

Tolerance: $\pm 2\text{mm}$

Scale: Not to Scale

Colour: Black

Title: Hose

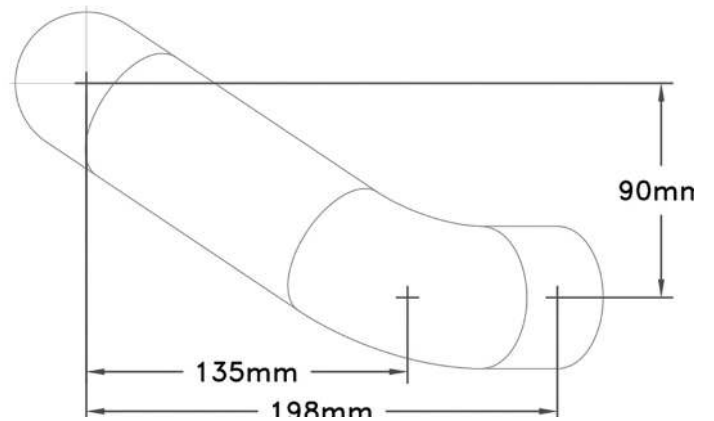
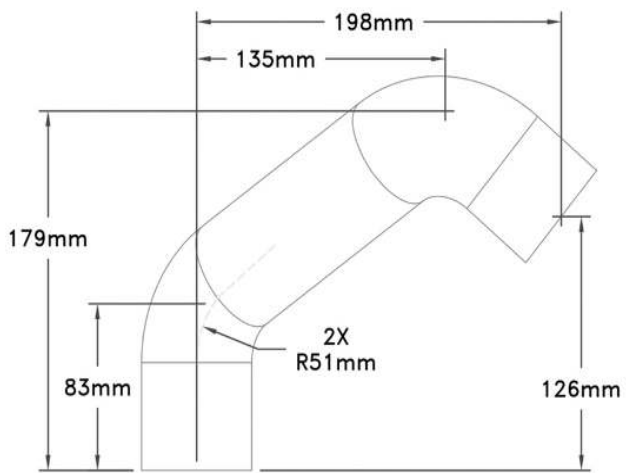

SILICONE HOSE CONNECTORS > HC-222-S

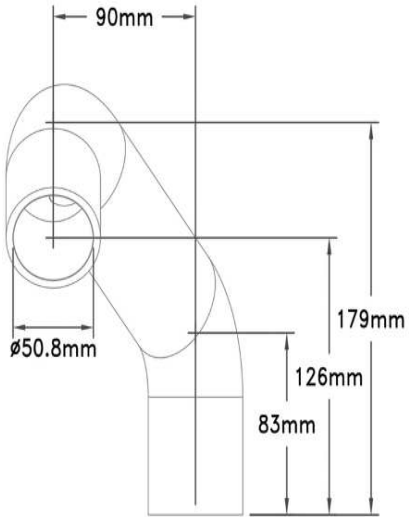

SILICONE HOSE CONNECTORS > HC-404-SI

SILICONE HOSE CONNECTORS PART #: HC-404-SI



Material: See note
Width: As shown
Height: As shown
Scale: Not to Scale

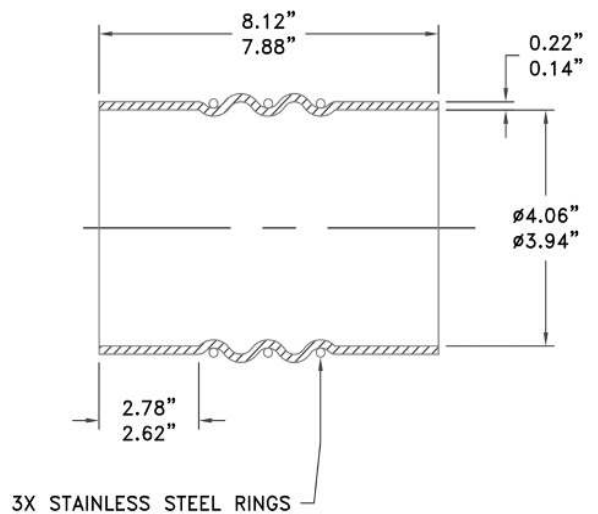
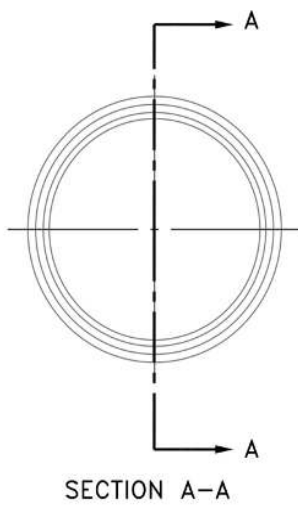

SILICONE HOSE CONNECTORS > HC-404-SI



SOLID PROFILES

SOLID PROFILES > ES08-525-N70



SOLID PROFILES PART #: ES08-525-N70

Material: Neoprene
Width: As shown
Height: As shown
Tolerance: RMA-E2
Scale: Not to Scale
Colour: Black
Duro: 70±5

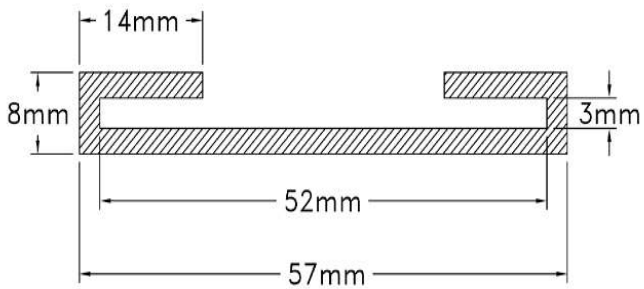

SOLID PROFILES > ES12-188-P80T1

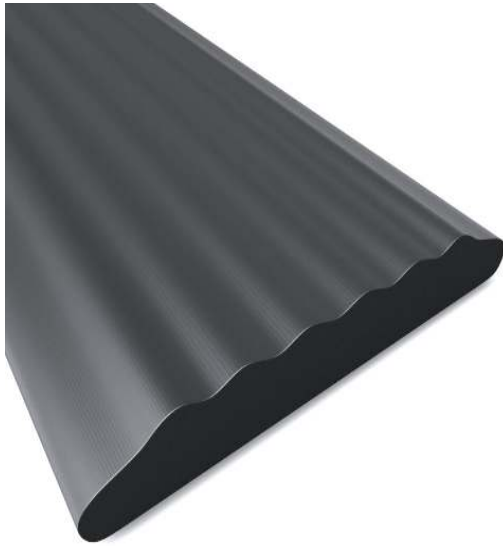

SOLID PROFILES PART #: ES12-188-P80T1

Material: PVC
Width: As shown
Height: As shown
Tolerance: RMA-E2
Scale: Not to Scale
Colour: Black Glossy
Duro: 80±5

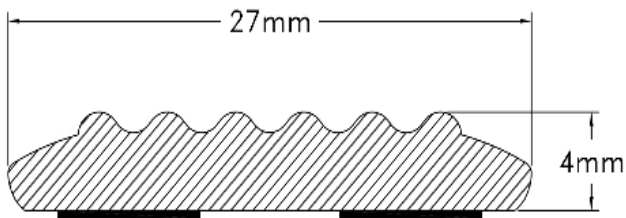

SOLID PROFILES > ES12-189-P80T1



SOLID PROFILES PART #: ES12-189-P80T1

Material: PVC
Width: As shown
Height: As shown
Tolerance: RMA-E2
Scale: Not to Scale
Colour: Black Matte
Duro: 80 ± 5

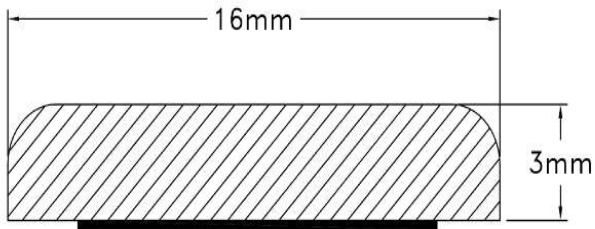

SOLID PROFILES > ES14-475-S60



SOLID PROFILES PART #: ES14-475-S60

Material: Silicone
Width: As shown
Height: As shown
Tolerance: RMA-E2
Scale: Not to Scale
Colour: Light Grey
Duro: 60±5

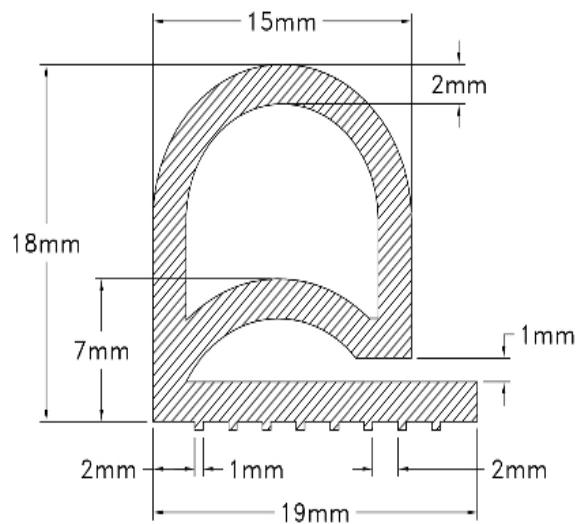

SOLID PROFILES > ES14-067-S60

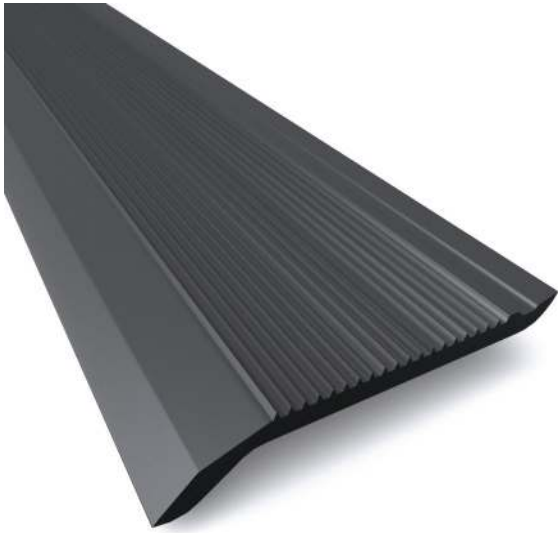

SOLID PROFILES PART #: ES14-067-S60

Material: Vinyl
Width: As shown
Height: As shown
Tolerance: RMA-E2
Scale: Not to Scale
Colour: Pantone 432 U
Duro: 90±5

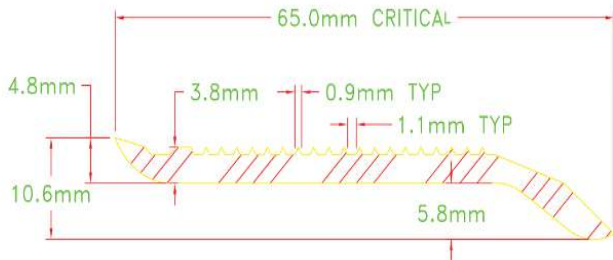

SOLID PROFILES > ES20-006-E60

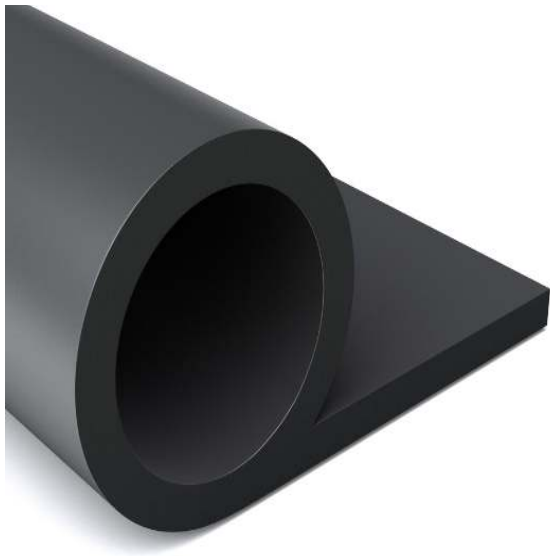

SOLID PROFILES PART #: ES20-006-E60

Material: EPDM
Width: As shown
Height: As shown
Tolerance: RMA-E2
Scale: Not to Scale
Colour: Black
Duro: 60±5

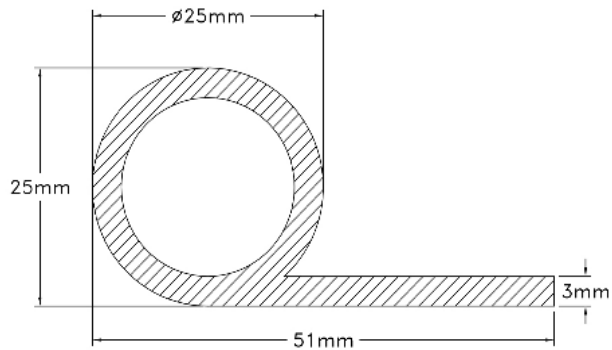

SOLID PROFILES > ES20-055-E70

SOLID PROFILES PART #: ES20-055-E70

Material: EPDM
Width: As shown
Height: As shown
Tolerance: RMA-E2
Scale: Not to Scale
Colour: Black
Duro: 70±5

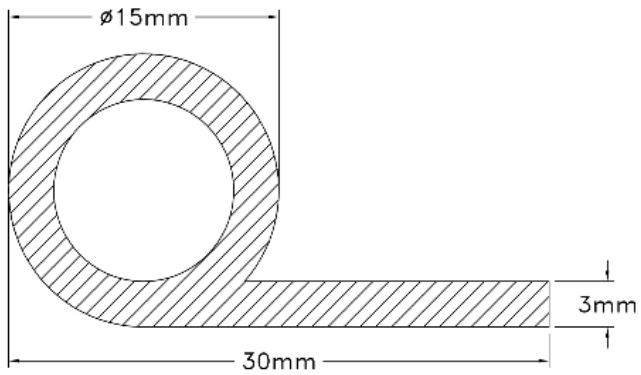

SOLID PROFILES > ES20-092-E70



SOLID PROFILES PART #: ES20-092-E70

Material: EPDM
Width: As shown
Height: As shown
Tolerance: RMA-E3
Scale: Not to Scale
Colour: Black
Duro: 70±5

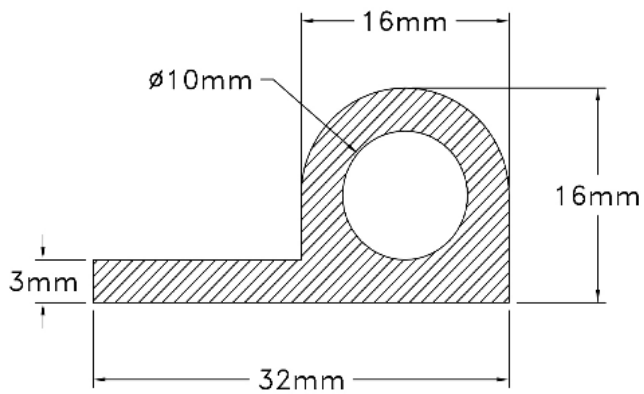

SOLID PROFILES > ES26-187-21-E60T1

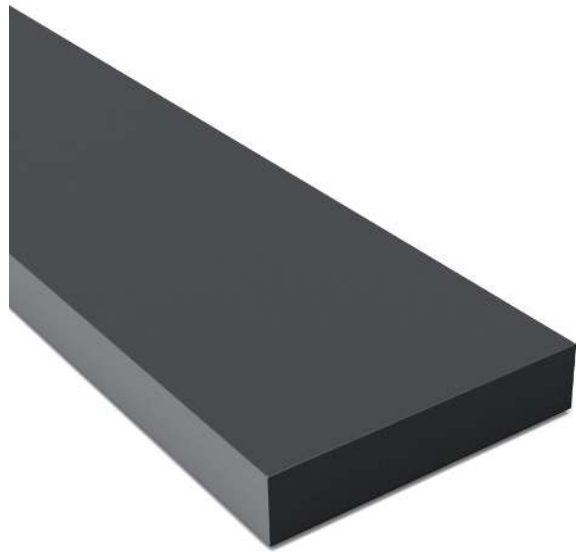

SOLID PROFILES

PART #: ES26-187-21-E60T1

Material: EPDM

Width: As shown

Height: As shown

Tolerance: As shown

Scale: Not to Scale

Colour: Black

Duro: 60±5

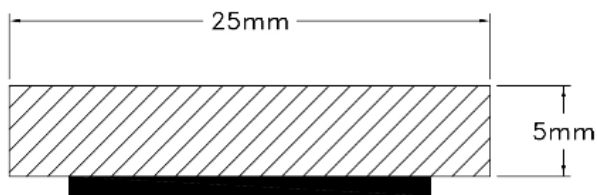

SOLID PROFILES > ES32-007-E70



SOLID PROFILES PART #: ES32-007-E70

Material: EPDM

Width: As shown

Height: As shown

Tolerance: RMA-E2

Scale: Not to Scale

Colour: Black

Duro: 70±5

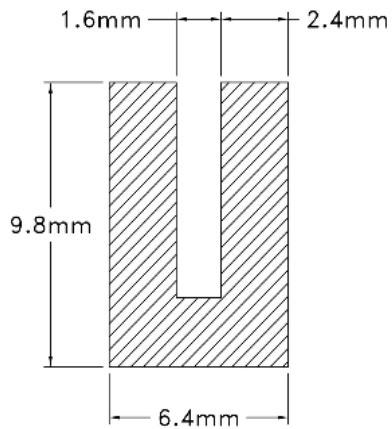

SOLID PROFILES > ES32-062-E70



SOLID PROFILES PART #: ES32-062-E70

Material: EPDM
Width: As shown
Height: As shown
Tolerance: RMA-E2
Scale: Not to Scale
Colour: Black
Duro: 70±5

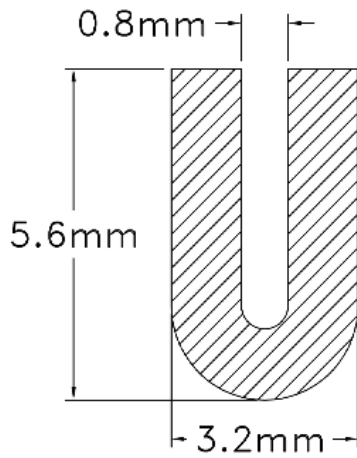

SOLID PROFILES > ES32-117-E70



SOLID PROFILES PART #: ES32-117-E70

Material: EPDM

Width: As shown

Height: As shown

Tolerance: RMA-E3

Scale: Not to Scale

Colour: Black

Duro: 70±5

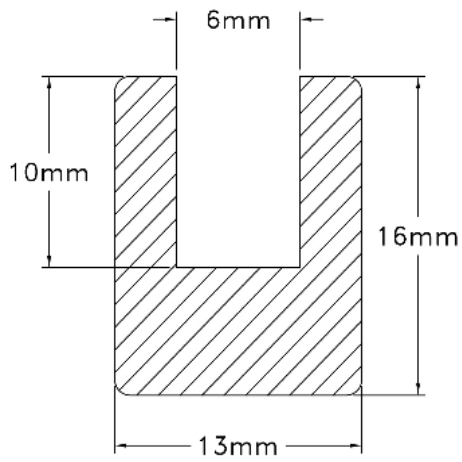

SOLID PROFILES > ES32-123-N70



SOLID PROFILES PART #: ES32-123-N70

Material: Neoprene
Width: As shown
Height: As shown
Tolerance: RMA-E3
Scale: Not to Scale
Colour: Black
Duro: 70±5

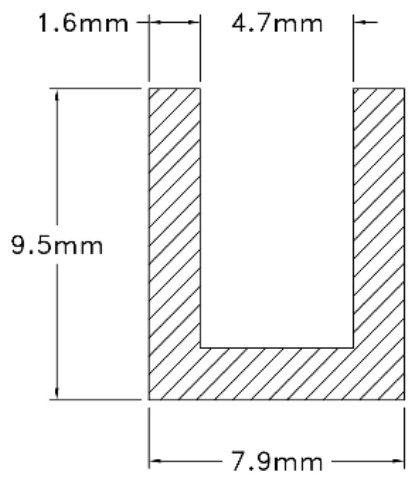

SOLID PROFILES > ES32-175-E70



SOLID PROFILES PART #: ES32-175-E70

Material: EPDM

Width: As shown

Height: As shown

Tolerance: RMA-E2

Scale: Not to Scale

Colour: Black

Duro: 70±5

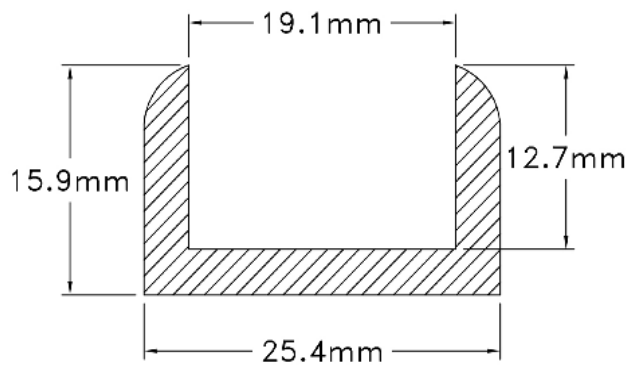

SOLID PROFILES > ES32-185-E60



SOLID PROFILES PART #: ES32-185-E60

Material: EPDM
Width: As shown
Height: As shown
Tolerance: RMA-E2
Scale: Not to Scale
Colour: Black
Duro: 60±5

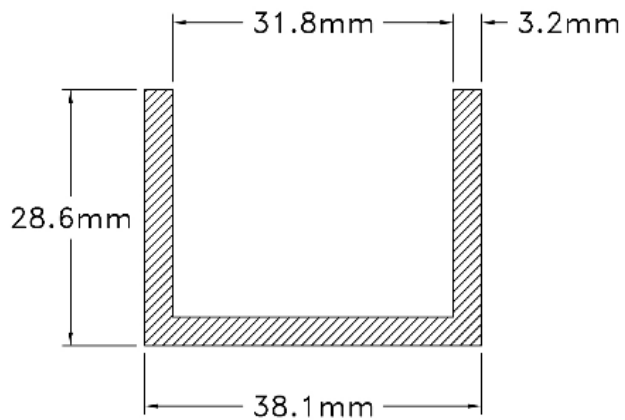

SPONGE PROFILES

SPONGE PROFILES > EC02-014-EM



SPONGE PROFILES PART #: EC02-014-EM

Material: EPDM
Width: As shown
Height: As shown
Tolerance: RMA-BEC2
Scale: Not to Scale
Colour: Black
Duro: Medium

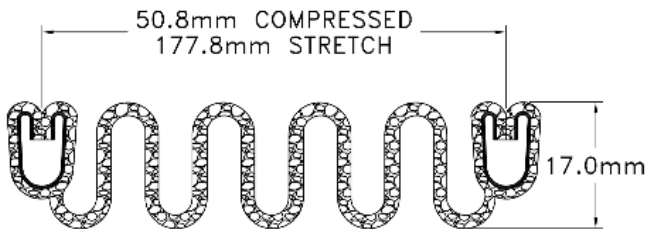

SPONGE PROFILES > EC02-025-EM



SPONGE PROFILES PART #: EC02-025-EM

Material: EPDM
Width: As shown
Height: As shown
Tolerance: RMA-E2
Scale: Not to Scale
Colour: Black
Duro: 70±5

50.8mm COMPRESSED
114.3mm STRETCHED

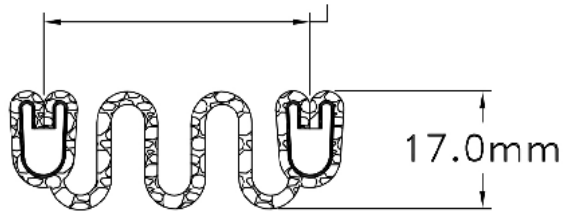

SPONGE PROFILES > EC04-006-EMT1



SPONGE PROFILES PART #: EC04-006-EMT1

Material: EPDM Sponge/PSA

Width: As shown

Height: As shown

Tolerance: As shown

Scale: Not to Scale

Colour: Black

Duro: Medium

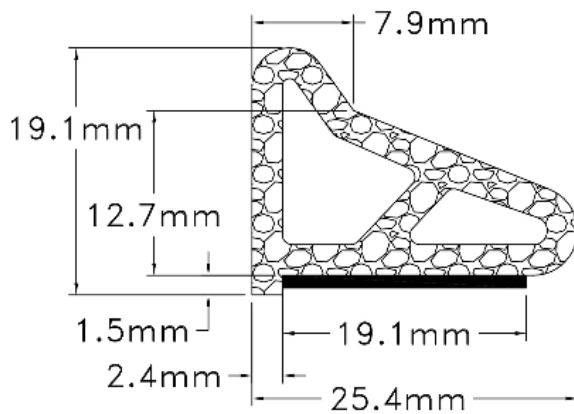

SPONGE PROFILES > EC04-130-EMT1



SPONGE PROFILES PART #: EC04-130-EMT1

Material: EPDM
Width: As shown
Height: As shown
Tolerance: RMA-BEC2
Scale: Not to Scale
Colour: Black
Duro: Medium

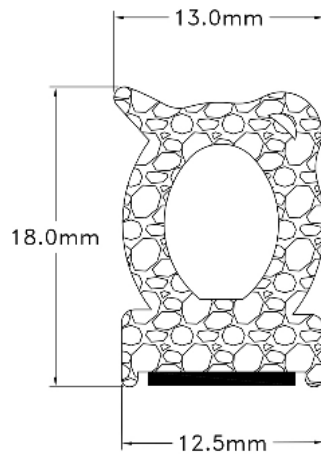

SPONGE PROFILES > EC12-005-EMT1



SPONGE PROFILES PART #: EC12-005-EMT1

Material: EPDM
Width: As shown
Height: As shown
Tolerance: RMA-BEC2
Scale: Not to Scale
Colour: Black
Duro: Medium

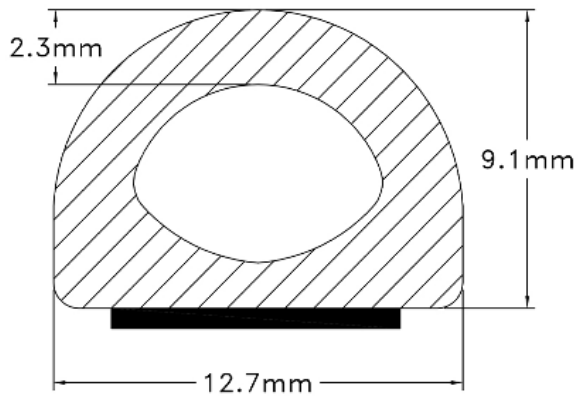

SPONGE PROFILES > EC12-006-EMT1



SPONGE PROFILES PART #: EC12-006-EMT1

Material: EPDM
Width: As shown
Height: As shown
Tolerance: RMA-BEC2
Scale: Not to Scale
Colour: Black
Duro: Medium

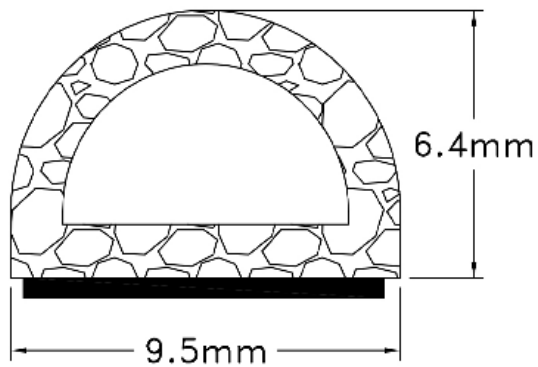

SPONGE PROFILES > EC12-009-EMT

SPONGE PROFILES PART #: EC12-009-EMT

Material: EPDM
Width: As shown
Height: As shown
Tolerance: TBA
Scale: Not to Scale
Colour: Black
Duro: Medium

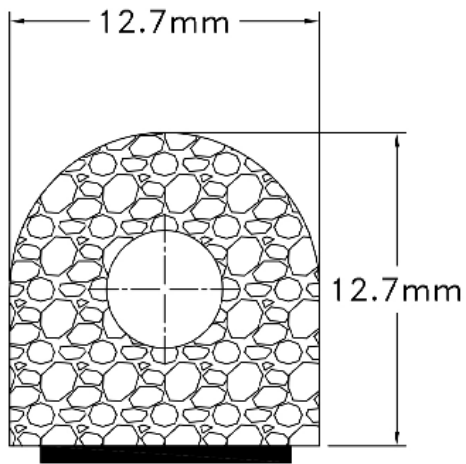

SPONGE PROFILES > EC12-010-MMT



SPONGE PROFILES PART #: EC12-010-MMT

Material: Blend Sponge

Width: As shown

Height: As shown

Tolerance: RMA-BEC2

Scale: Not to Scale

Colour: Black

Duro: Medium

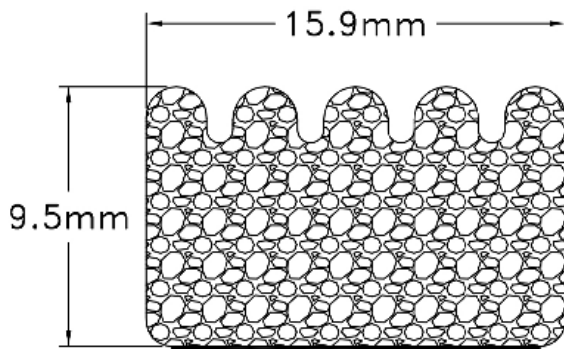

SPONGE PROFILES > EC12-012-EMT

SPONGE PROFILES PART #: EC12-012-EMT

Material: EPDM
Width: As shown
Height: As shown
Tolerance: As shown
Scale: Not to Scale
Colour: Black
Duro: Medium

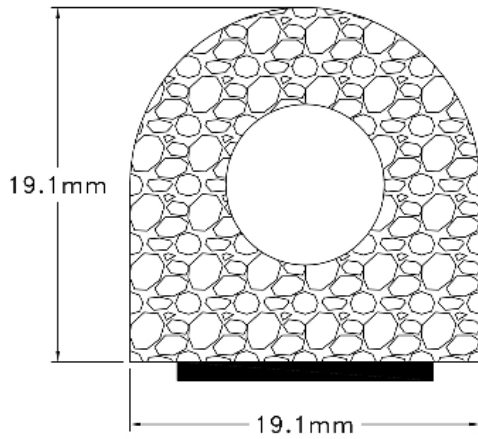

SPONGE PROFILES > EC12-013-NMT



SPONGE PROFILES PART #: EC12-013-NMT

Material: Neoprene
Width: As shown
Height: As shown
Tolerance: As shown
Scale: Not to Scale
Colour: Black
Duro: Medium

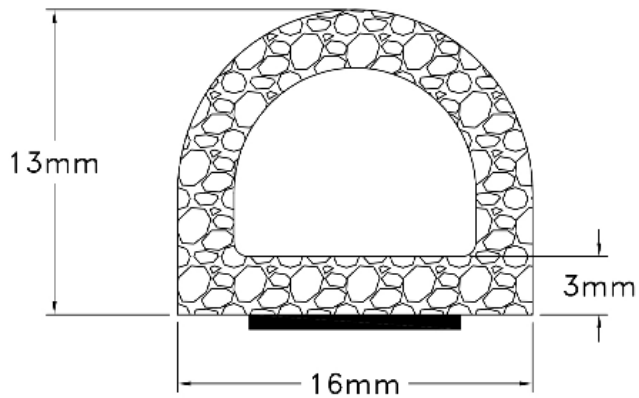

SPONGE PROFILES > EC12-015-EMT1



SPONGE PROFILES PART #: EC12-015-EMT1

Material: EPDM
Width: As shown
Height: As shown
Tolerance: RMA-BEC2
Scale: Not to Scale
Colour: Black
Duro: Medium

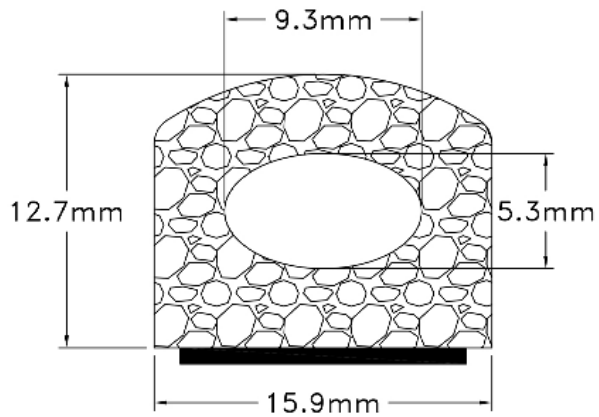

SPONGE PROFILES > EC12-016-EMT1



SPONGE PROFILES PART #: EC12-016-EMT1

Material: EPDM
Width: As shown
Height: As shown
Tolerance: TBA
Scale: Not to Scale
Colour: Black
Duro: Medium

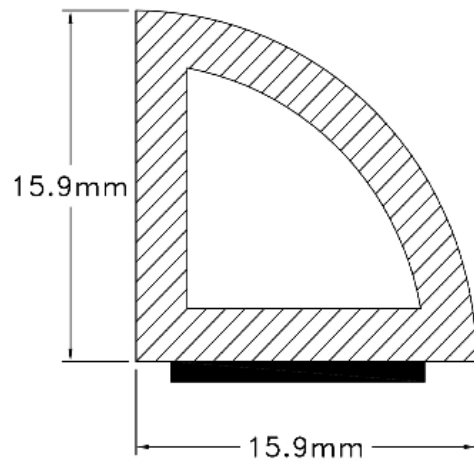

SPONGE PROFILES > EC12-017-EMT1



SPONGE PROFILES PART #: EC12-017-EMT1

Material: EPDM
Width: As shown
Height: As shown
Tolerance: RMA-BER2
Scale: Not to Scale
Colour: Black
Duro: Medium

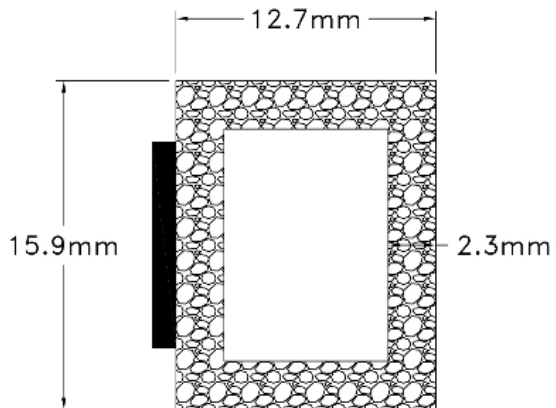

SPONGE PROFILES > EC12-020-EMT1



SPONGE PROFILES PART #: EC12-020-EMT1

Material: EPDM
Width: As shown
Height: As shown
Tolerance: TBA
Scale: Not to Scale
Colour: Black
Duro: Medium

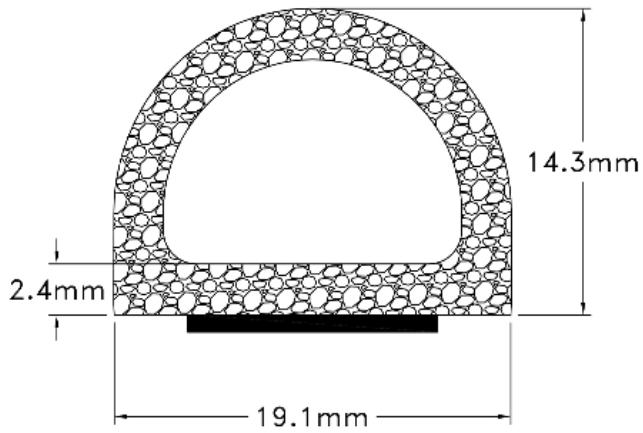

SPONGE PROFILES > EC12-045-EHT1



SPONGE PROFILES PART #: EC12-045-EHT1

Material: EPDM
Width: As shown
Height: As shown
Tolerance: RMA-BEC2
Scale: Not to Scale
Colour: Black
Duro: Hard

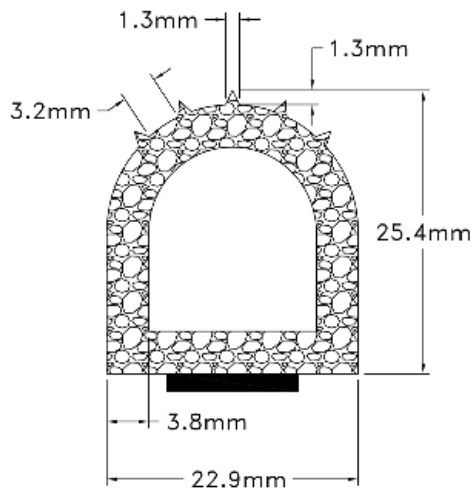

SPONGE PROFILES > EC12-046-EMT1



SPONGE PROFILES PART #: EC12-046-EMT1

Material: EPDM Sponge
Width: As shown
Height: As shown
Tolerance: RMA-BEC2
Scale: Not to Scale
Colour: Black
Duro: Medium

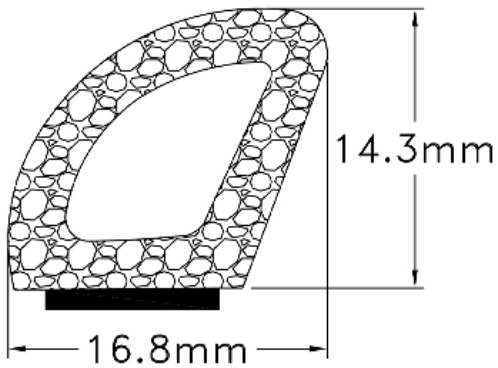

SPONGE PROFILES > EC12-049-MMT1



SPONGE PROFILES PART #: EC12-049-MMT1

Material: Blend Sponge
Width: As shown
Height: As shown
Tolerance: RMA-BER2
Scale: Not to Scale
Colour: Black
Duro: Medium

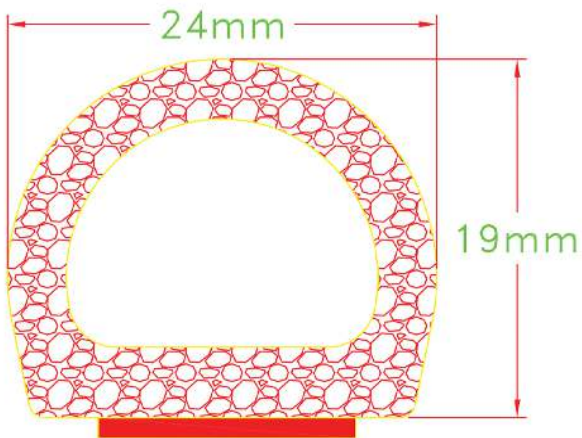

SPONGE PROFILES > EC12-050-EMT1

SPONGE PROFILES PART #: EC12-050-EMT1

Material: EPDM Sponge
Width: As shown
Height: As shown
Tolerance: As shown
Scale: Not to Scale
Colour: Black
Duro: Medium

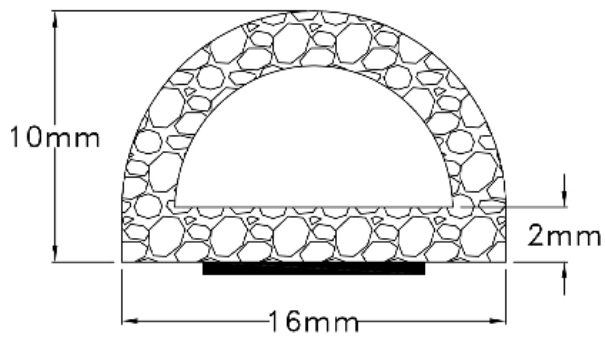

SPONGE PROFILES > EC12-055-EMT1



SPONGE PROFILES PART #: EC12-055-EMT1

Material: EPDM
Width: As shown
Height: As shown
Tolerance: RMA-BEC2
Scale: Not to Scale
Colour: Black
Duro: Medium

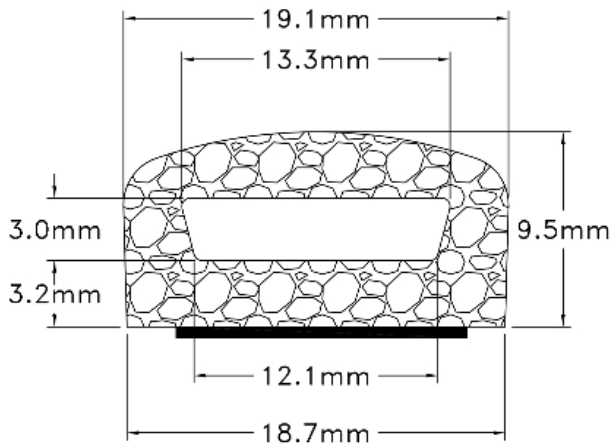

SPONGE PROFILES > EC12-065-EMT1



SPONGE PROFILES PART #: EC12-065-EMT1

Material: EPDM
Width: As shown
Height: As shown
Tolerance: RMA-BEC2
Scale: Not to Scale
Colour: Black
Duro: Medium

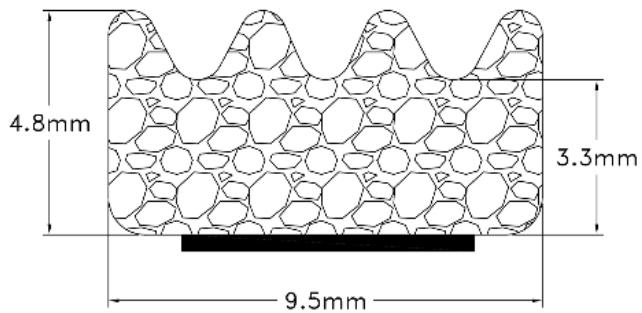

SPONGE PROFILES > EC12-506-EMT1

SPONGE PROFILES PART #: EC12-506-EMT1

Material: EPDM Sponge
Width: As shown
Height: As shown
Tolerance: RMA-BEC2
Scale: Not to Scale
Colour: Black
Duro: Medium

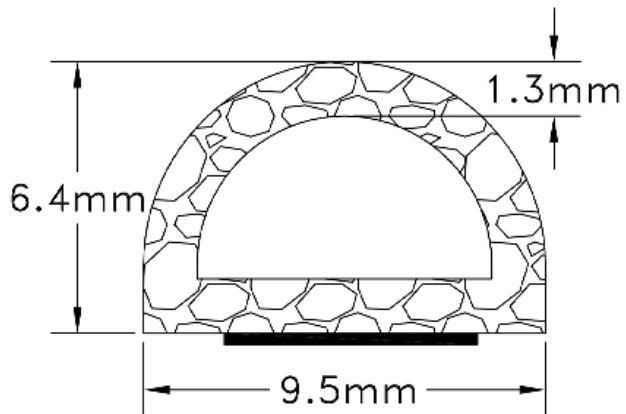

SPONGE PROFILES > EC12-545-EMT1



SPONGE PROFILES PART #: EC12-545-EMT1

Material: EPDM
Width: As shown
Height: As shown
Tolerance: RMA-BEC2
Scale: Not to Scale
Colour: Black
Duro: Medium

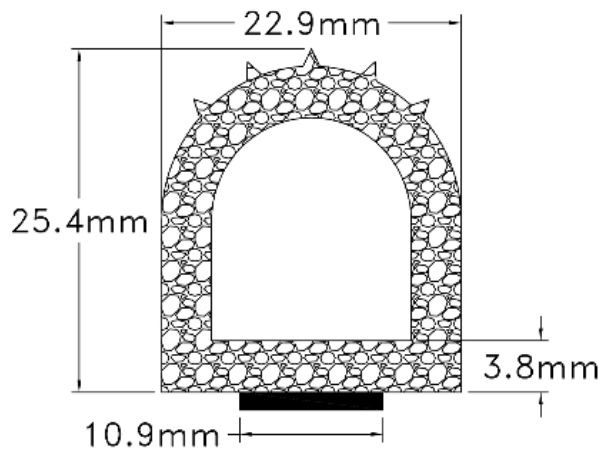

SPONGE PROFILES > EC14-014-EM



SPONGE PROFILES PART #: EC14-014-EM

Material: EPDM/NEO/CPE Blend

Width: As shown

Height: As shown

Tolerance: RMA-BEC2

Scale: Not to Scale

Colour: Black

Duro: Medium

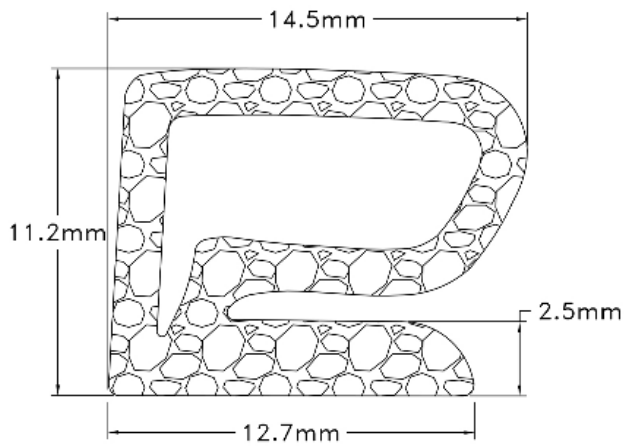

SPONGE PROFILES > EC26-031-EST



SPONGE PROFILES PART #: EC26-031-EST

Material: EPDM
Width: As shown
Height: As shown
Tolerance: RMA-BEC2
Scale: Not to Scale
Colour: Black
Duro: Soft

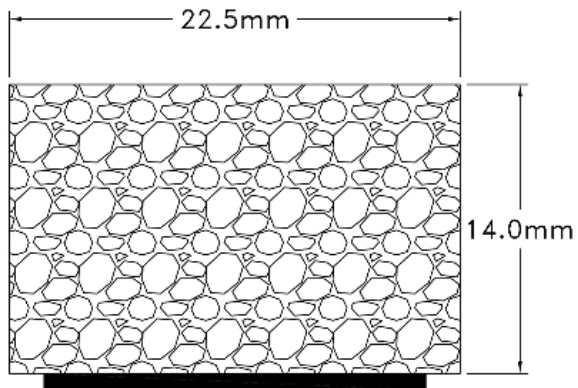

WINDOW CHANNELS

WINDOW CHANNELS > ES35-019-E60

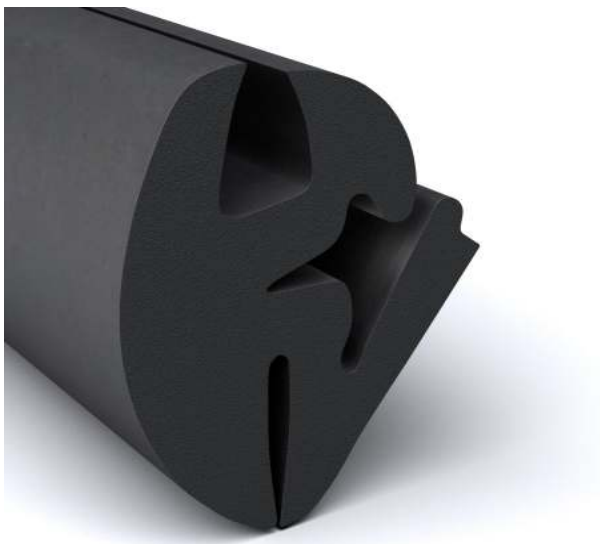

WINDOW CHANNELS PART #: ES35-019-E60

Material: EPDM
Width: As shown
Height: As shown
Tolerance: RMA-E2
Scale: Not to Scale
Colour: Black
Duro: 60±5

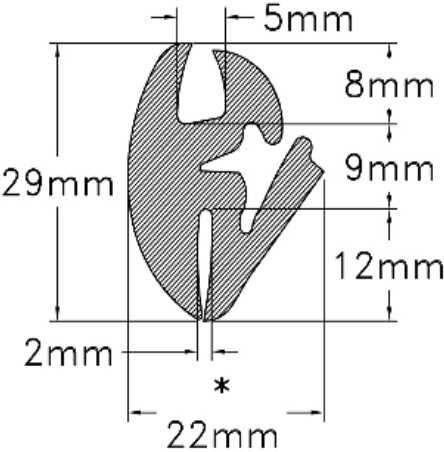

WINDOW CHANNELS > ES35-020-E70



WINDOW CHANNELS PART #: ES35-020-E70

Material: EPDM
Width: As shown
Height: As shown
Tolerance: As shown
Scale: Not to Scale
Colour: Black
Duro: 70±5

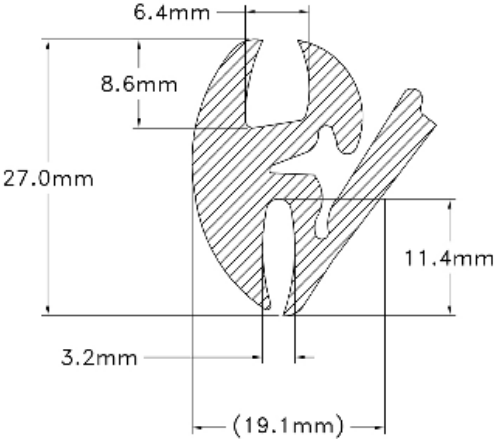

WINDOW CHANNELS > ES35-022-E65



WINDOW CHANNELS PART #: ES35-022-E65

Material: EPDM
Width: As shown
Height: As shown
Tolerance: RMA-E3
Scale: Not to Scale
Colour: Black
Duro: 65±5

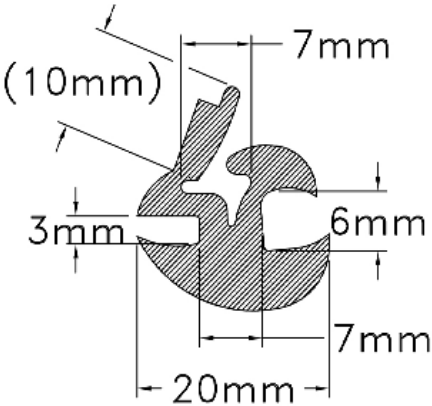

WINDOW CHANNELS > ES36-014-E70



WINDOW CHANNELS PART #: ES36-014-E70

Material: EPDM
Width: As shown
Height: As shown
Tolerance: RMA-E2
Scale: Not to Scale
Colour: Black
Duro: 70±5

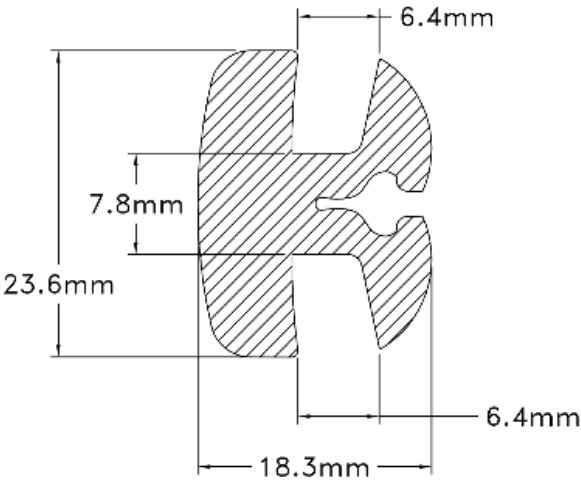

WINDOW CHANNELS > ES36-034-E70



WINDOW CHANNELS PART #: ES36-034-E70

Material: EPDM

Width: As shown

Height: As shown

Tolerance: RMA-E2

Scale: Not to Scale

Colour: Black

Duro: 70±5

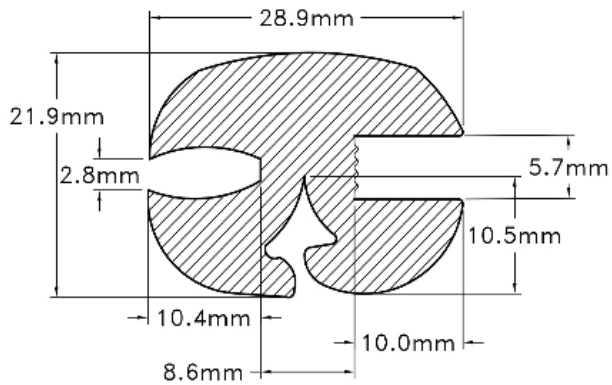

WINDOW CHANNELS > ES38-002-E80



WINDOW CHANNELS PART #: ES38-002-E80

Material: EPDM
Width: As shown
Height: As shown
Tolerance: RMA-E2
Scale: Not to Scale
Colour: Black
Duro: 80±5

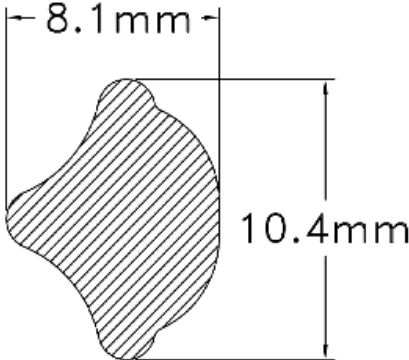

FOR MORE INFORMATION:
ELASTOPROXY.COM



OUR COMMITMENT

When Elasto Proxy makes a commitment, we promise to fully understand your needs and deliver on them. It begins with listening to you and analyzing your needs. It continues by comparing our production capabilities to your application requirements. Unlike other fabricators of industrial rubber products, Elasto Proxy is your partner in the manufacturing process.

We only accept the jobs we can do, and we always complete them to the highest standards. Business relationships are commitments, and we promise to act on your behalf and serve your interests. So let Elasto Proxy apply its flexible and innovative application knowledge for you. Choose a partner – not just a provider.



OUR TECHNOLOGY

- Abrasive Waterjet Cutting Machine
- CNC Waterjet Cutting Machine
- "C-Press" Molding Machine
- Film Splicing Machine
- Vulcanizing Machine
- PSA + HSA Taping Machine
- Acoustic Laboratory

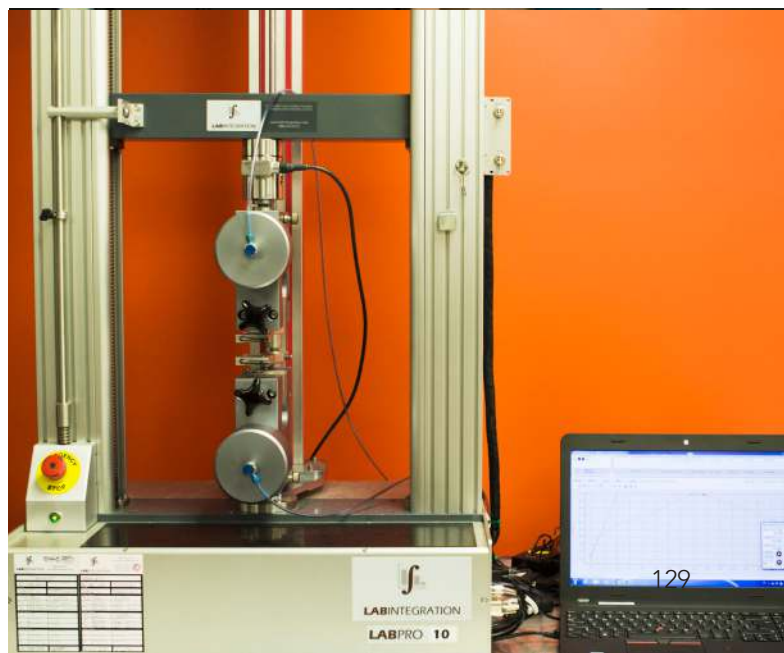
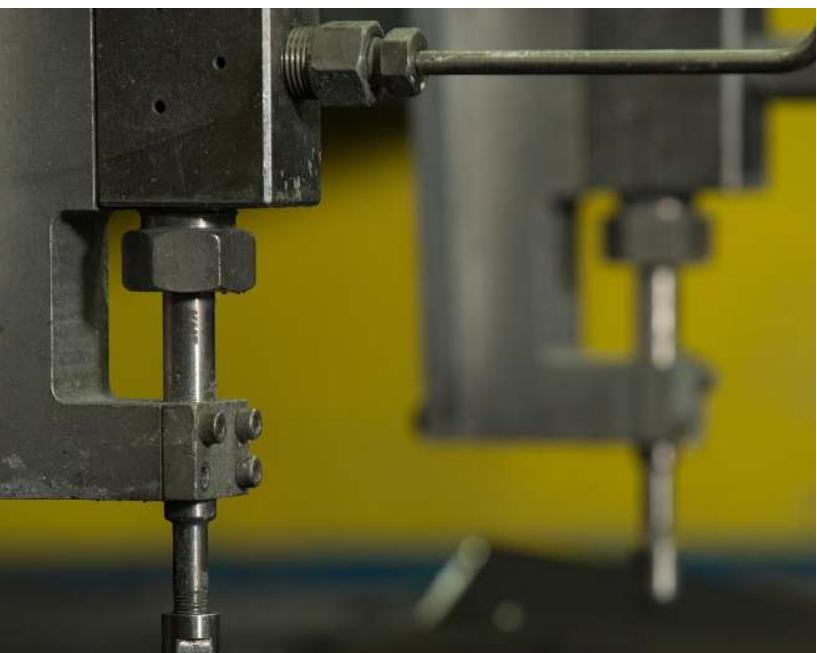
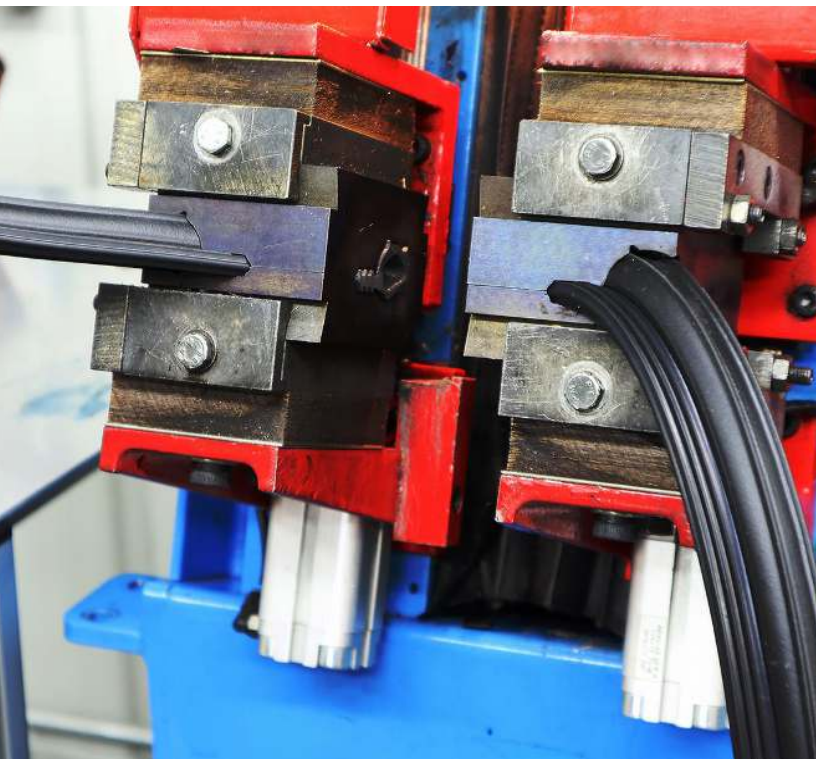

PRODUCT OFFERING

PUSH ON PROFILES

- Bulb Trim
- Edge Trim
- U-Channel
- Window Channel



MOLDED PARTS

- Bumpers
- Vibration Mounts
- Molded Plastic & Rubber Parts



MECHANICALLY FASTENED PROFILES

- E-Shape Profiles
- P-Shape Profiles



ADHESIVE BACKED PROFILES

- Sponge Profiles
- D-Shape Profiles



INSULATION & SHEETING

- Cab Insulation
- Floor Matting
- Engine Insulation



OTHER PRODUCTS

- Tubing
- Weather Stripping
- Silicone Hose Connectors



FINISHED GASKETS

Elasto Proxy is a gasket fabricator that provides cold bonding, C-press injection molding, hot splicing, and vulcanizing services. We use water jet cutting to create fine, fast cuts that are ready to bond with whatever joining method you require. We also add value by providing design assistance and help with material selection.

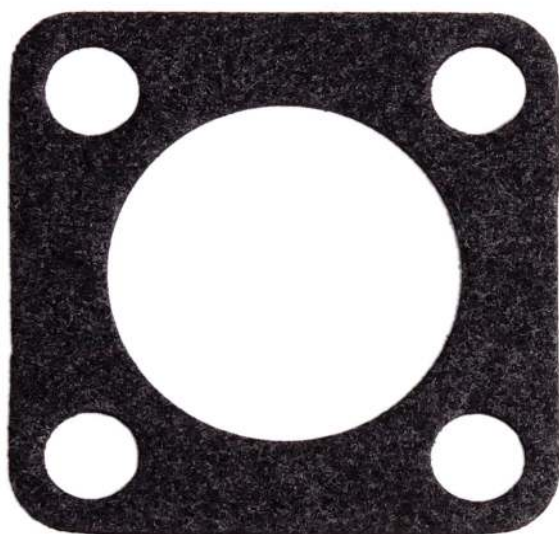

ADDED VALUE SERVICES





WAREHOUSING SERVICES

Elasto Proxy's warehousing services help you to reduce risks and control costs. We also make it easy to get all of the rubber and plastic products that you need from a single supplier. From rubber coils to finished gaskets and from plastic parts to thermal-acoustic insulation, Elasto Proxy is your one-stop solution for sealing out supply chain problems and insulating against uncertainty.

Just-in-time inventory is risky these days. If you're buying from distant suppliers, you may not be able to get what you need or get it on-time. When you buy from Elasto Proxy, however, we can order all of the materials that you'll need for months (or even a year) and store everything in one of our North American or European warehouses. Just provide us with your production forecast or with a blanket purchase order.

Because Elasto Proxy's warehouses are conveniently located, you won't have to worry about waiting for overseas shipments to arrive. In addition, because Elasto Proxy won't bill you until we ship your products, our warehouse services let you conserve cash flow while still taking advantage of volume discounts. Storing your products with us saves space at your facility, too.

Importantly, Elasto Proxy's warehousing services let you get all of the rubber and plastic products that you need from one trusted supplier. That means fewer vendor scorecards to maintain and less vendor data to manage for items that you only buy periodically. You can also combine our warehousing services with kitting and assembly packaging to increase your operational efficiency.

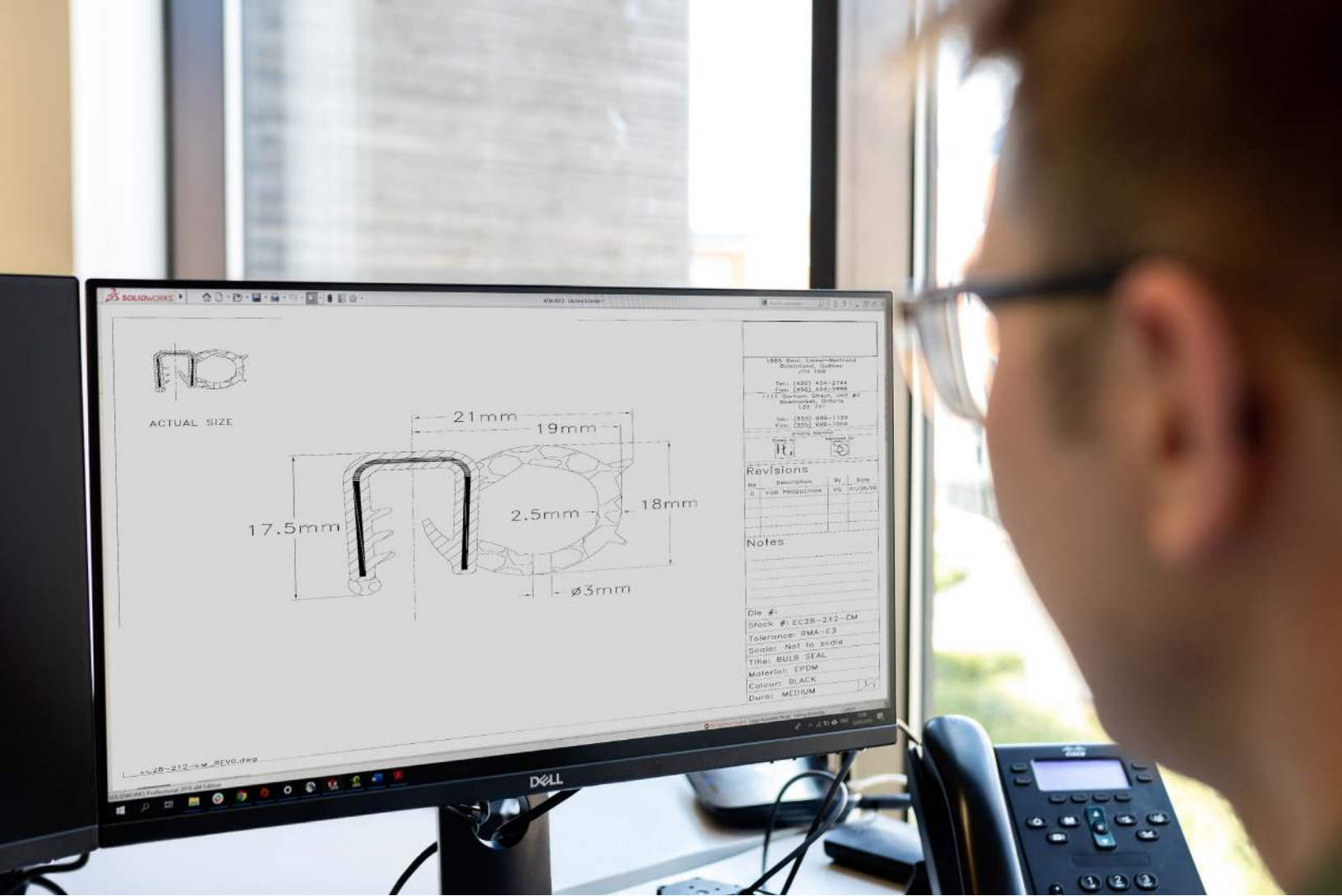

DESIGN ASSISTANCE

Elasto Proxy can help you design the sealing and insulation solutions that you need. For example, if you're designing a custom gasket, we can help you determine the size of the gap and the shape of the profile. We can also help you choose the right material in the proper hardness, or durometer. Plus, we'll talk to you about how media, temperature, application, and pressure (MTAP) affect gasket design.

Like any discipline, rubber has its own language. ASTM D2000, an industry specification that uses letters and numbers to call out the properties of vulcanized rubber, provides a standard way to talk about elastomers. That's important because asking for "black rubber" doesn't provide enough detail. When you work with Elasto Proxy, however, we'll translate your requirements into application-specific solutions.

If you're designing thermal or acoustic insulation instead, Elasto Proxy also offers design assistance. Whether you need protection against heat, sound, or both, our solutions providers can recommend the right materials and the best way to put them together. With the sandwich-style insulation that we build, you'll get a complete thermal-acoustic solution.

In addition, Elasto Proxy can help you with design for manufacturing (DFM). Rubber has different tolerances than metal, so we'll talk to you about the part tolerances to put on drawings. We can also suggest ways to nest parts in order to maximize material yields. With our in-house taping capabilities, we can even suggest better ways to achieve temporary or permanent fastening.

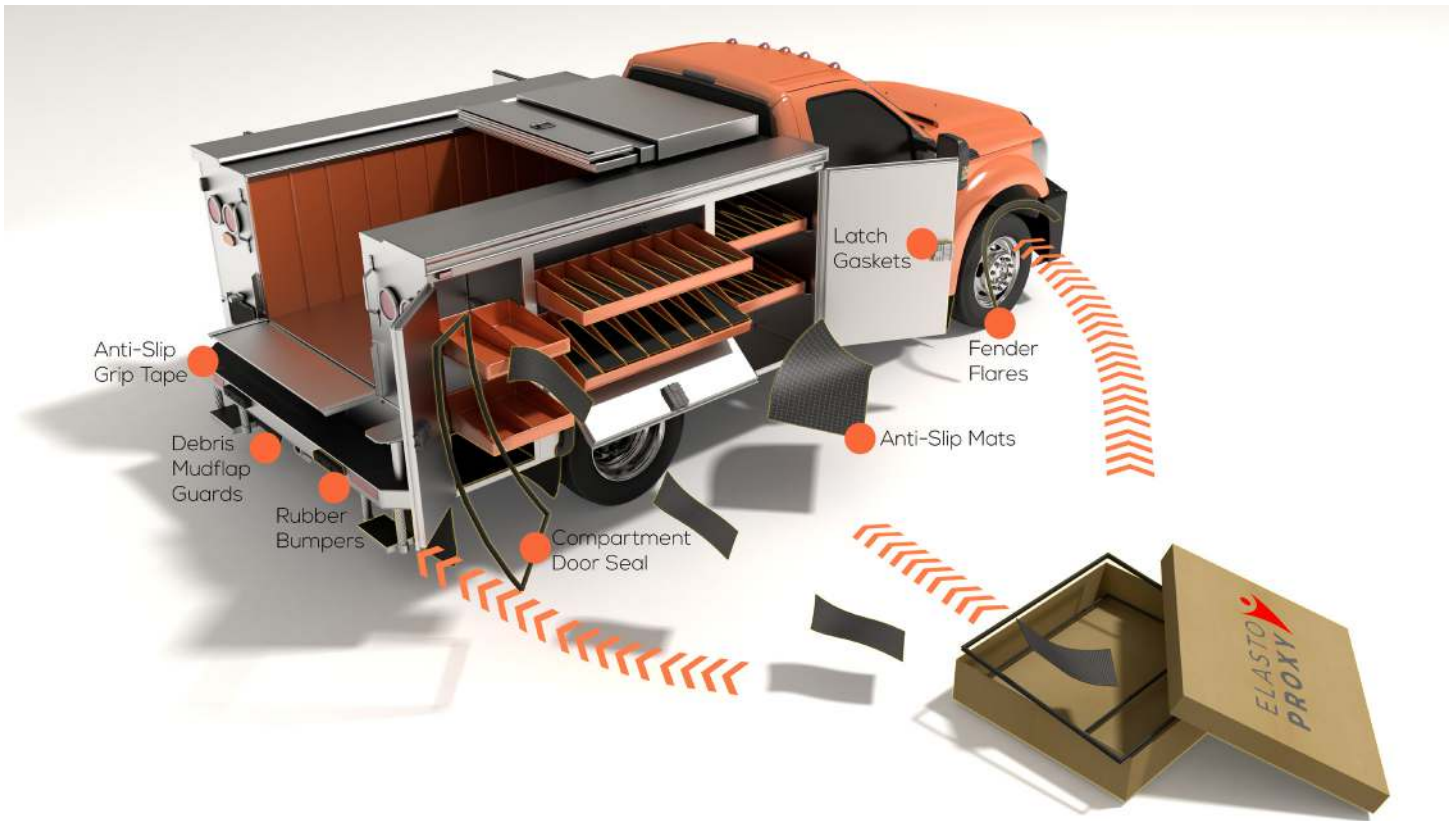

KITTING AND ASSEMBLY PACKAGING

Kitting groups two or more related products together to create a new stocking unit (SKU). SKUs promote efficiency, but it's possible to have too much of a good thing. Manufacturers with too many SKUs spend more time finding, sorting, handling, and organizing stock. This adds labor costs and requires more storage space. A large number of SKUs can also tie-up cash in inventory and increase your tax liabilities.

Kitting from Elasto Proxy reduces your SKUs along with your risks and expenses. Related items are packaged together so that they can be ordered, received, warehoused, and used at the same time. For example, let's say you want to order and receive all of the sealing and insulation that's needed for a build. When it's time for product assembly, there's only one SKU for all of the build's rubber and plastic parts.

With kits, parts are packaged together and shipped in the same box. These parts can be arranged in a particular order or dumped in the box at random. When kitted parts are packaged in order of assembly, however, installers can work more efficiently. There's no need to search for the part to install first or the part to install next. That's where assembly packaging from Elasto Proxy saves you both time and money.

Consider some of the benefits of arranging kitted parts in order of installation. When you open the box, the part you need to install first is on top. The part you need to install next is below the first part, and so on. It's easier for installers – and the benefits extend across the enterprise from purchasing and receiving to inventory and accounting.

FABRICATION SERVICES



FABRICATION SERVICES

WATER JET

Abrasive water jet cutting mixes water with garnet abrasive in a high-pressure, high-velocity stream that can cut harder, thicker materials such as sheets and profiles made of rubber, plastic, metal, stone, and glass.

Elasto Proxy uses this form of water jet technology to cut:

- Hard materials
- Thick, soft materials
- Rubber products that contain metal wires



LAMINATING

Laminating creates custom insulation sandwiches, composite structures that contain multiple layers of rubber sheets that impart particular properties. Depending on your application requirements, Elasto Proxy can create acoustic insulation, thermal insulation, or thermal-acoustic insulation.

BONDED GASKETS

Bonding joins the ends of rubber profiles into finished gaskets. Examples include bezel or picture-frame style gaskets, rounded gaskets, and O-rings.

Elasto Proxy offers a choice of bonding methods:

- Hot Splicing
- Vulcanizing
- Cold Bonding
- Molding



GET IN TOUCH

CANADA

4035 Lavoisier Rue
Boisbriand, Québec,
Canada
J7H 1N1

Phone: (450) 434-2744
Fax: (450) 434-5998

CANADA

1145 Nicholson RD Unit 3
Newmarket, Ontario,
Canada
L3Y 9C3

Phone: (905) 898-1139
Fax: (905) 898-1004

USA

1021-C Old Stage Road
Simpsonville, South
Carolina, USA
29681-6044

Phone: (864) 228-5900
Fax: (864) 963-8992

BELGIUM

Heimolenstraat 127A
Unit 5, 9100 Sint-Niklaas

Phone: +32 (0) 3 301 01 83